



# **HV580 Series Frequency Inverter User Manual**



# Contents

<b>Contents .....</b>	<b>2</b>
<b>Chapter 1 Safety Information and Precautions .....</b>	<b>4</b>
1.1 Safety Information .....	4
1.2 General Precautions.....	7
<b>Chapter 2 Product Information .....</b>	<b>10</b>
2.1 Designation Rules and Nameplate of the HV580 .....	10
2.2 Nameplates .....	10
2.3 HV580 Variable-frequency Drive series .....	11
2.4 Technical specifications .....	12
2.5 Variable-frequency Drive rated output current .....	16
<b>Chapter 3 Mechanical and Electrical Installation.....</b>	<b>17</b>
3.1 Mechanical Installation.....	17
3.2 Electrical Installation.....	22
<b>Chapter 4 Operation, Display and Application Examples .....</b>	<b>28</b>
4.1 Operation Panel.....	28
4.2 Description of keys on the operation panel .....	30
<b>Chapter 5 Function Code Table.....</b>	<b>32</b>
<b>Chapter 6 Description of Function Codes .....</b>	<b>72</b>
Group P0: Basic Parameters .....	72
Group P1: Motor 1 Parameters .....	84
Group P2: Vector Control Parameters.....	90
Group P3: V/F Control Parameters .....	93
Group P4: Input Terminals.....	99
Group P5: Output Terminals.....	113
Group P6 Start/Stop Control.....	119
Group P7 Operation Panel and Display .....	124
Group P8 Auxiliary Functions.....	128

Group P9 Fault and Protection .....	139
Group PA: Process Control PID Function .....	149
Group PB: Swing Frequency, Fixed Length and Count.....	155
Group PC: Multi-Reference and Simple PLC Function .....	158
Group PD: Communication parameters .....	164
Group PP: User’s password.....	164
Group A0: Torque Control and Restricting Parameters.....	166
Group C Monitor.....	168
<b>Chapter 7 Maintenance and Troubleshooting .....</b>	<b>170</b>
7.1 Routine Repair and Maintenance of the HV580.....	170
7.2 Warranty Agreement .....	172
7.3 Faults and Solutions.....	172
7.4 Common Faults and Solutions .....	179
<b>Appendix A    :    RS-485communication expansion card instruction .....</b>	<b>183</b>
<b>AppendixB    :    HV580 Modbus communication .....</b>	<b>184</b>
<b>Warranty Agreement.....</b>	<b>196</b>

# Chapter 1 Safety Information and Precautions

In this manual, the notices are graded based on the degree of danger:

-  DANGER indicates that failure to comply with the notice will result in severe personal injury or even death.
-  WARNING indicates that failure to comply with the notice will result in personal injury or property damage.

Read this manual carefully so that you have a thorough understanding. Installation, commissioning or maintenance may be performed in conjunction with this chapter. HNC Electric will assume no liability or responsibility for any injury or loss caused by improper operation.

## 1.1 Safety Information

Use Stage	Safety Grade	Precautions
Before installation	DANGER	<ul style="list-style-type: none"> <li>• Do not install the equipment if you find water seepage, component missing or damage upon unpacking.</li> <li>• Do not install the equipment if the packing list does not conform to the product you.</li> </ul>
	WARNING	<ul style="list-style-type: none"> <li>• Handle the equipment with care during transportation to prevent damage to the equipment.</li> <li>• Do not use the equipment if any component is damaged or missing.</li> <li>Failure to comply will result in personal injury.</li> <li>• Do not touch the components with your hands. Failure to comply will result in static electricity damage.</li> </ul>
During installation	DANGER	<ul style="list-style-type: none"> <li>• Install the equipment on incombustible objects such as metal, and keep it away from combustible materials. Failure to comply may result in a fire.</li> <li>• Do not loosen the fixed screws of the components, especially the screws with red mark.</li> </ul>

### HV580 Series Frequency Inverter

	WARNING	<ul style="list-style-type: none"> <li>• Do not drop wire end or screw into the AC drive. Failure to comply will result in damage to the AC drive.</li> <li>• Install the AC drive in places free of vibration and direct sunlight.</li> <li>• When two AC drives are laid in the same cabinet, arrange the installation positions properly to ensure the cooling effect.</li> </ul>
At wiring	DANGER	<ul style="list-style-type: none"> <li>• Wiring must be performed only by qualified personnel under instructions described in this manual. Failure to comply may result in unexpected accidents.</li> <li>• A circuit breaker must be used to isolate the power supply and the AC drive. Failure to comply may result in a fire.</li> <li>• Ensure that the power supply is cut off before wiring. Failure to comply may result in electric shock.</li> <li>• Tie the AC drive to ground properly by standard. Failure to comply may result in electric shock.</li> </ul>
	WARNING	<ul style="list-style-type: none"> <li>• Never connect the power cables to the output terminals (U, V, W) of the AC drive. Pay attention to the marks of the wiring terminals and ensure correct wiring. Failure to comply will result in damage to the AC drive.</li> <li>• Never connect the braking resistor between the DC bus terminals (+) and (-). Failure to comply may result in a fire.</li> <li>• Use wire sizes recommended in the manual. Failure to comply may result in accidents.</li> <li>• Use a shielded cable for the encoder, and ensure that the shielding layer is reliably grounded.</li> </ul>
Before power-on	DANGER	<ul style="list-style-type: none"> <li>• Check that the following requirements are met:               <ul style="list-style-type: none"> <li>– The voltage class of the power supply is consistent with the rated voltage class of the AC drive.</li> <li>– The input terminals (R, S, T) and output terminals (U, V, W) are properly connected.</li> <li>– No short-circuit exists in the peripheral circuit.</li> <li>– The wiring is secured.</li> </ul> </li> </ul> <p>Failure to comply will result in damage to the AC drive</p> <ul style="list-style-type: none"> <li>• Do not perform the voltage resistance test on any part of the AC drive because such test has been done in the factory. Failure to comply will result in accidents.</li> </ul>

### HV580 Series Frequency Inverter

	WARNING	<ul style="list-style-type: none"> <li>• Cover the AC drive properly before power-on to prevent electric shock.</li> <li>• All peripheral devices must be connected properly under the instructions described in this manual. Failure to comply will result in accidents.</li> </ul>
After power-on	DANGER	<ul style="list-style-type: none"> <li>• Do not open the AC drive's cover after power-on. Failure to comply may result in electric shock.</li> <li>• Do not touch any I/O terminal of the AC drive. Failure to comply may result in electric shock.</li> </ul>
	WARNING	<ul style="list-style-type: none"> <li>• Do not touch the rotating part of the motor during the motor auto-tuning or running. Failure to comply will result in accidents.</li> <li>• Do not change the default settings of the AC drive. Failure to comply will result in damage to the AC drive.</li> </ul>
During operation	DANGER	<ul style="list-style-type: none"> <li>• Do not touch the fan or the discharging resistor to check the temperature. Failure to comply will result in personal burnt.</li> <li>• Signal detection must be performed only by qualified personnel during operation. Failure to comply will result in personal injury or damage to the AC drive.</li> </ul>
	WARNING	<ul style="list-style-type: none"> <li>• Avoid objects falling into the AC drive when it is running. Failure to comply will result in damage to the AC drive.</li> <li>• Do not start/stop the AC drive by turning the contactor ON/OFF. Failure to comply will result in damage to the AC drive.</li> </ul>

## HV580 Series Frequency Inverter

During maintenance	<b>DANGER</b>	<ul style="list-style-type: none"> <li>• Repair or maintenance of the AC drive may be performed only by qualified personnel. Failure to comply will result in personal injury or damage to the AC drive.</li> <li>• Do not repair or maintain the AC drive at power-on. Failure to comply will result in electric shock.</li> <li>• Repair or maintain the AC drive only ten minutes after the AC drive is powered off. This allows for the residual voltage in the capacitor to discharge to a safe value. Failure to comply will result in personal injury.</li> <li>• Ensure that the AC drive is disconnected from all power supplies before starting repair or maintenance on the AC drive.</li> <li>• Set and check the parameters again after the AC drive is replaced.</li> <li>• All the pluggable components must be plugged or removed only after power-off.</li> <li>• The rotating motor generally feeds back power to the AC drive.</li> </ul> <p>As a result, the AC drive is still charged even if the motor stops, and the power supply is cut off. Thus ensure that the AC drive is disconnected from the motor before starting repair or maintenance on the AC drive.</p>
--------------------	---------------	--

## 1.2 General Precautions

### 1) Motor insulation test

Perform the insulation test when the motor is used for the first time, or when it is reused after being stored for a long time, or in a regular check-up, in order to prevent the poor insulation of motor windings from damaging the AC drive. The motor must be disconnected from the AC drive during the insulation test. A 500-V mega-Ohm meter is recommended for the test. The insulation resistance must not be less than 5 MΩ.

### 2) Thermal protection of motor

If the rated capacity of the motor selected does not match that of the AC drive, especially when the AC drive's rated power is greater than the motor's, adjust the motor protection parameters on the operation panel of the AC drive or install a thermal relay in the motor circuit for protection.

### 3) Running at over 50 Hz

The AC drive provides frequency output of 0 to 3200 Hz (Up to 300 Hz is supported if the AC drive runs in CLVC and SFVC mode). If the AC drive is required to run at over 50 Hz, consider the capacity of the machine.

### 4) Vibration of mechanical device

The AC drive may encounter the mechanical resonance point at some output frequencies, which can be avoided by setting the skip frequency.

**5) Motor heat and noise**

The output of the AC drive is pulse width modulation (PWM) wave with certain harmonic frequencies, and therefore, the motor temperature, noise, and vibration are slightly greater than those when the AC drive runs at power frequency (50 Hz).

**6) When external voltage is out of rated voltage range**

The AC drive must not be used outside the allowable voltage range specified in this manual. Otherwise, the AC drive's components may be damaged. If required, use a corresponding voltage step-up or step-down device.

**7) Contactor at the I/O terminal of the AC drive**

When a contactor is installed between the input side of the AC drive and the power supply, the AC drive must not be started or stopped by switching the contactor on or off. If the AC drive has to be operated by the contactor, ensure that the time interval between switching is at least one hour since frequent charge and discharge will shorten the service life of the capacitor inside the AC drive.

When a contactor is installed between the output side of the AC drive and the motor, do not turn off the contactor when the AC drive is active. Otherwise, modules inside the AC drive may be damaged.

**8) When external voltage is out of rated voltage range**

The AC drive must not be used outside the allowable voltage range specified in this manual. Otherwise, the AC drive's components may be damaged. If required, use a corresponding voltage step-up or step-down device.

**9) Prohibition of three-phase input changed into two-phase input**

Do not change the three-phase input of the AC drive into two-phase input. Otherwise, a fault will result or the AC drive will be damaged.

**10) Lightning shock protection**

This series of frequency converter is equipped with a lightning over current protection device, for induction lightning has certain ability of self-protection, but for frequent lightning place customers should also be adding lightning protection devices in inverter front.

**11) Altitude and de-rating**

In places where the altitude is above 1000 m and the cooling effect reduces due to thin air, it is necessary to de-rate the AC drive. Contact HNC Electric for technical support.

**12) Some special usages**

If wiring that is not described in this manual such as common DC bus is applied, contact the agent or HNC Electric for technical support.

**13) Disposal**

The electrolytic capacitors on the main circuits and PCB may explode when they are burnt. Poisonous gas is



generated when the plastic parts are burnt. Treat them as ordinary industrial waste

#### **14) Adaptable Motor**

- The standard adaptable motor is adaptable four-pole squirrel-cage asynchronous induction motor or PMSM. For other types of motor, select a proper AC drive according to the rated motor current.
- The cooling fan and rotor shaft of non-variable-frequency motor are coaxial, which results in reduced cooling effect when the rotational speed declines. If variable speed is required, add a more powerful fan or replace it with variable-frequency motor in applications where the motor overheats easily.
- The standard parameters of the adaptable motor have been configured inside the AC drive. It is still necessary to perform motor auto-tuning or modify the default values based on actual conditions. Otherwise, the running result and protection performance will be affected.
- The AC drive may alarm or even be damaged when short-circuit exists on cables or inside the motor. Therefore, perform insulation short-circuit test when the motor and cables are newly installed or during routine maintenance. During the test, make sure that the AC drive is disconnected from the tested parts.

## Chapter 2 Product Information

### 2.1 Designation Rules and Nameplate of the HV580

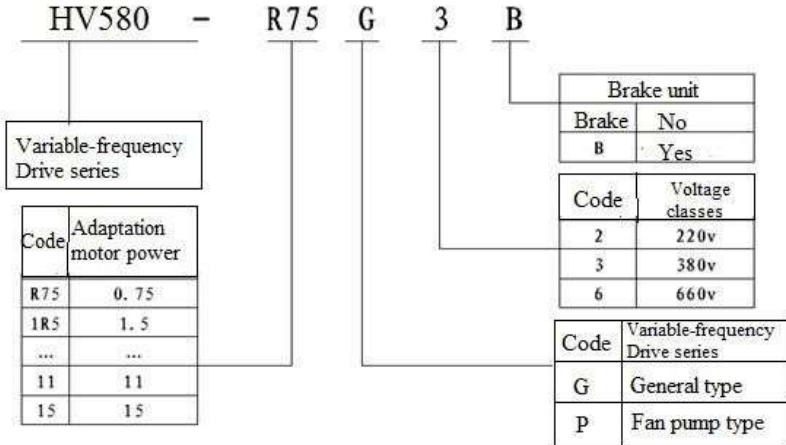

### 2.2 Nameplates

<b>MODEL:</b>	<b>HV580-R75G3B</b>
<b>POWER:</b>	<b>0.75KW</b>
<b>INPUT:</b>	<b>3PH AC380V 3.4A 50Hz/60Hz</b>
<b>OUTPUT:</b>	<b>3PH AC 0~380V 2.4A 0~300Hz</b>
<b>S/N:</b>	Bar code

### 2.3 HV580 Variable-frequency Drive series

Figure 2-1 HV 580 Inverter model and technical data

Variable frequency Drive type	Power Capacity KVA	Input Current A	Output current A	Adapter motor	
				Kw	HP
Three-phase supply: 380V, 50/60Hz					
HV580-R75G3B	1.5	3.4	2.1	0.75	1
HV580-1R5G3B	3.0	5.0	3.8	1.5	2
HV580-2R2G3B	4.0	5.8	5.1	2.2	3
HV580-3R7G3B	5.9	10.5	9.0	3.7	5
HV580-5R5G3B    HV580-5R5P3B	8.9	14.6	13.0	5.5	7.5
HV580-7R5G3B    HV580-7R5P3B	11.0	20.5	17	7.5	10
HV580-011G3B    HV580-011P3B	17.0	26.0	25.0	11.0	15
HV580-015G3B    HV580-015P3B	21.0	35.0	32.0	15.0	20
HV580-018G3B    HV580-018P3B	24.0	38.5	37.0	18.5	25
HV580-022G3B    HV580-022P3B	30.0	46.5	45.0	22	30
HV580-030G3B    HV580-030P3B	40.0	62.0	60.0	30	40
HV580-037G3B    HV580-037P3B	57.0	76.0	75.0	37	50
HV580-045G3B    HV580-045P3B	69.0	92.0	91.0	45	60
HV580-055G3B    HV580-055P3B	85.0	113.0	112.0	55	70
HV580-075G3B    HV580-075P3B	114.0	157.0	150.0	75	100
HV580-090G3B    HV580-090P3B	134.0	180.0	176.0	90	125
HV580-110G3B    HV580-110P3B	160.0	214.0	210.0	110	150
HV580-132G3B    HV580-132P3B	192.0	256.0	253.0	132	175
HV580-160G3B    HV580-160P3B	231.0	307.0	304.0	160	210
HV580-200G3B    HV580-200P3B	250.0	385.0	377.0	200	260
HV580-220G3B    HV580-220P3B	280.0	430.0	426.0	220	300
HV580-250G3B    HV580-250P3B	355.0	468.0	465.0	250	350
HV580-280G3B    HV580-280P3B	396.0	525.0	520.0	280	370
HV580-315G3B    HV580-315P3B	445.0	590.0	585.0	315	500
HV580-355G3B    HV580-355P3B	500.0	665.0	650.0	355	420

### HV580 Series Frequency Inverter

HV580-400G3B	HV580-400P3B	565.0	785.0	725.0	400	530
HV580-450P3B		630.0	883.0	820.0	450	600

## 2.4 Technical specifications

Figure 2-2 Technical specifications of the HV580

Item	Specifications		
Standard functions	Maximum frequency	• Vector control: 0–300 Hz • V/F control: 0–320 Hz	
	Carrier	0.5–16 kHz	
	Frequency	The carrier frequency is automatically adjusted based on the load features.	
	Input frequency	Digital setting: 0.01 Hz	
	Resolution	Analog setting: maximum frequency x 0.025%	
	Control mode	<ul style="list-style-type: none"> <li>• Sensorless flux vector control (SFVC)</li> <li>• Closed-loop vector control (CLVC)</li> <li>• Voltage/Frequency (V/F) control</li> </ul>	
	Startup torque	<ul style="list-style-type: none"> <li>• G type: 0.5 Hz/150% (SFVC); 0 Hz/180% (CLVC)</li> <li>• P type: 0.5 Hz/100%</li> </ul>	
	Speed range	1:100 (SVC)	1:1000 (FVC)
	Speed stability	±0.5% (SVC)	±0.02% (FVC)
	Torque control	±5% (FVC)	
	Overload capacity	<ul style="list-style-type: none"> <li>• G type: 60s or 150% of the rated current, 3s for 180% of the rated current</li> <li>• P type: 60s for 120% of the rated current, 3s for 150% of the rated current</li> </ul>	
	Torque boost	<ul style="list-style-type: none"> <li>• Fixed boost</li> <li>• Customized boost 0.1%–30.0%</li> </ul>	
	V/F curve	<ul style="list-style-type: none"> <li>• Straight-line V/F curve</li> <li>• Multi-point V/F curve</li> <li>• N-power V/F curve (1.2-power, 1.4-power, 1.6-power, 1.8-power, square)</li> </ul>	
	V/F separation	Two types: complete separation; half separation	
	Ramp mode	<ul style="list-style-type: none"> <li>• Straight-line ramp</li> <li>• S-curve ramp</li> </ul> Four groups of acceleration/deceleration time with the range of 0.0–6500.0s	
DC braking	DC braking frequency: 0.00 Hz to maximum frequency Braking time: 0.0–36.0s Braking action current value: 0.0%–100.0%		

### HV580 Series Frequency Inverter

	JOG control	JOG frequency range: 0.00–50.00 Hz JOG acceleration/deceleration time: 0.0–6500.0s
	Onboard multiple preset	It implements up to 16 speeds via the simple PLC function or combination of DI terminal states.
	Onboard PID	It realizes process-controlled closed loop control system easily.
	Auto voltage regulation	It can keep constant output voltage automatically when the mains voltage changes.
	Over voltage/ Over current stall Control	The current and voltage are limited automatically during the running process so as to avoid frequent tripping due to over voltage/over current.
	Fast current limiting function	Minimizing over-current fault protect the normal operation of the inverter
	Torque limit and control	It can limit the torque automatically and prevent frequent over current tripping during the running process. Torque control can be implemented in the CLVC mode.
Individualized functions	High performance	Control of asynchronous motor and synchronous motor are implemented through the high-performance current vector control technology.
	Power dip ride Through	The load feedback energy compensates the voltage reduction so that the AC drive can continue to run for a short time.
	Rapid current limit	It helps to avoid frequent over current faults of the AC drive.
	Virtual I/Os	Five groups of virtual DI/Dos can realize simple logic control.
	Timing control	Time range: 0.0–6500.0 minutes
	Multi-motor switchover	Four motors can be switched over via four groups of motor parameters.
	Multiple communication	It supports communication via Modbus -RTU, PROFIBUSDP, CAN link and CAN open.
	Motor overheat Protection	The optional I/O extension card enables AI3 to receive the motor temperature sensor input (PT100, PT1000) so as to realize motor overheat protection.

### HV580 Series Frequency Inverter

	Multiple encoder Types	It supports various encoders such as differential encoder, open-collector encoder, resolver, UVW encoder, and SIN/COS encoder.
--	------------------------	--

Item	Specifications	
RUN	Running command source	<ul style="list-style-type: none"> <li>• Operation panel</li> <li>• Control terminals</li> <li>• Serial communication port</li> </ul> You can perform switchover between these sources in various ways.
	Frequency source	There are a total of 10 frequency sources, such as digital setting, analog voltage setting, analog current setting, pulse setting and serial communication port setting.  You can perform switchover between these sources in various ways.
	Auxiliary frequency source	There are ten auxiliary frequency sources. It can implement fine tuning of auxiliary frequency and frequency synthesis.
	Input terminal	Standard: 5 digital input (DI) terminals, one of which supports up to 100 kHz high-speed pulse input 2 analog input (AI) terminals, one of which only supports 0–10 V voltage input and the other supports 0–10 V voltage input or 4–20 m A current input  Expanding capacity: 5 DI terminals 1 AI terminal that supports -10–10 V voltage input and also supports PT100\PT1000

### HV580 Series Frequency Inverter

	Output terminal	<p>Standard</p> <p>1 high-speed pulse output terminal (open-collector) that supports 0–100 kHz square wave signal output</p> <p>1 digital output (DO) terminal</p> <p>1 relay output terminal</p> <p>1 analog output (AO) terminal that supports 0–20 m A current output or 0–10 V voltage output</p> <p>Expanding capacity:</p> <p>1 DO terminal</p> <p>1 relay output terminal</p> <p>1 AO terminal that supports 0–20 m A current output or 0–10 V voltage output</p>
Item	Specifications	Item
Display and operation on the operation panel	LED display	It displays the parameters.
	LCD displaying	Optional parts, Chinese/English Prompt action content
	Parameters of the copy	Achieved through the LCD operation panel option parameters of rapid replication
	Key locking and function selection	It can lock the keys partially or completely and define the function range of some keys so as to prevent mis-function.
	Protection mode	Motor short-circuit detection at power-on, input/output phase loss protection, over current protection, over voltage protection, under voltage protection, overheat protection and overload protection
Environment	Installation Location	Indoor, free from direct sunlight, dust, corrosive gas, combustible gas, oil smoke, vapour, drip or salt.
	Altitude	Lower than 1000 m
	Ambient Temperature	-10°C to +40°C (de-rated if the ambient temperature is between 40°C and 50°C)
	Humidity	Less than 95%RH, without condensing

### HV580 Series Frequency Inverter

	Vibration	Less than 5.9 m/s <sup>2</sup> (0.6 g)
	Storage Temperature	- 20°C ~ + 60°C
	IP level	IP20
	Pollution degree	PD2
	Power distribution System	TN , TT

## 2.5 Variable-frequency Drive rated output current

Figure 2-3 Variable-frequency Drive rated output current

Input voltage	220V	380V	660V	1140V
Rated power	Rated output current (A)			
0.4	2.5			
0.75	4	2.3		
1.5	7	3.7		
2.2	10	5.0		
3.7	16	8.5		
5.5	20	13		
7.5	30	17	10	
11	42	25	15	
15	55	32	18	
18.5	70	38	22	
22	80	45	28	
30	110	60	35	
37	130	75	45	25
45	160	90	52	31
55	200	110	63	38
75	260	150	86	52
93	320	180	98	58
110	380	210	121	75
132	420	250	150	86



HV580 Series Frequency Inverter

160	550	310	175	105
185	600	340	198	115
200	660	380	218	132
220	720	415	235	144
250		470	270	162
280		510	330	175
315		600	345	208
355		670	380	220
400		750	430	260
450		810	466	270
500		860	540	325
560		990	600	365
630		1100	680	400

## Chapter 3 Mechanical and Electrical Installation

### 3.1 Mechanical Installation

#### 3.1.1 Installation Environment Requirements

1. Ambient temperature  $-10^{\circ}\text{C}\sim 40^{\circ}\text{C}$ , Well ventilated or indoor Spaces with ventilation devices, more than 40 °C derating use. Avoid vibration, direct sunlight, away from heat source.
2. AC drives can install where altitude 1000 m below the output rated power, when more than 1000 m altitude need derating use, specific derating range, please contact the company.
3. Avoid high temperature high humidity, the humidity is less than 90% RH (Non-condensate).
4. Apart from the oil, salt and corrosive gas. To prevent water, steam, dust, lint, metal powder.
5. Prevent electromagnetic interference, away from the interference sources.
6. It is prohibited to use in flammable, explosive gas, liquid or solid dangerous environment.

#### 3.1.2 Installation Clearance Requirements

The clearance that needs to be reserved varies with the power class of the HV580, as shown in the following

figure.

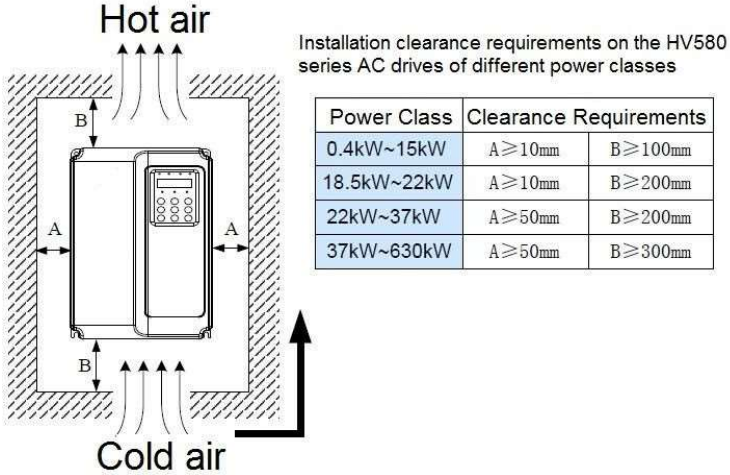

The HV580 series AC drive dissipates heat from the bottom to the top. When multiple AC drives are required to work together, install them side by side.

For application installing multiple AC drives, if one row of AC drives need to be installed above another row, install an insulation guide plate to prevent AC drives in the lower row from heating those in the upper row and causing faults.

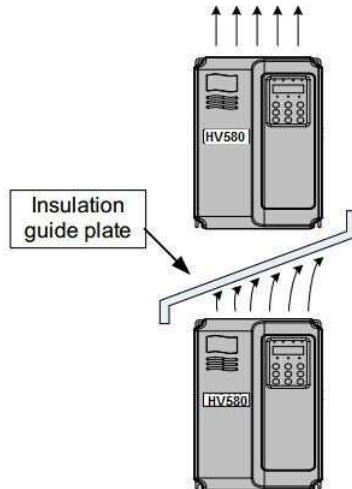

### 3.1.3 Mounting dimension

1) Online example

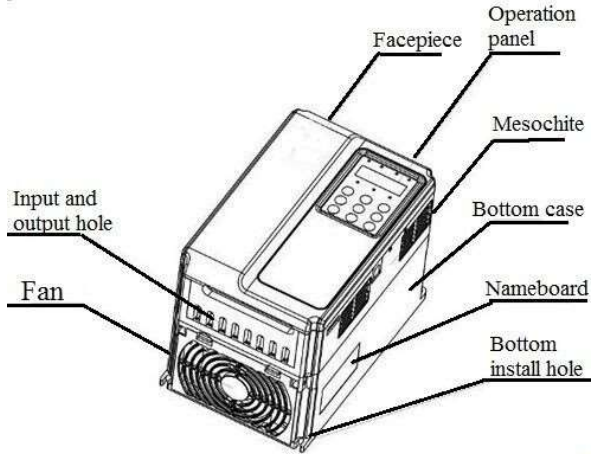

Figure 3-1 HV580 series online example

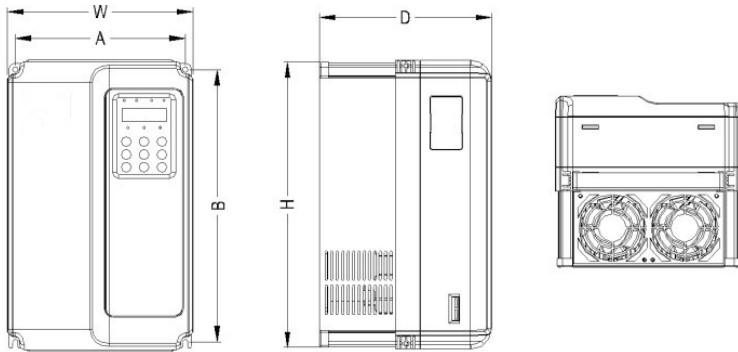

Figure 3-2 HV580 series Plastic structure shape dimension and installation dimension sketch

2) HV580series VFD Mounting dimension and Mounting position size (mm)

3-1 Exterior and Mouting position size

VFD type	Mounting position mm		External dimension mm			Mounting position diameter mm	Weight Kg
	A	B	H	W	D		

### HV580 Series Frequency Inverter

Three phase 380V							
HV580-R75G3B	113	172	186	125	164	φ5.0	1.1
HV580-1R5G3B							
HV580-2R2G3B							
HV580-3R7G3B	148	236	248	160	183	φ5.0	2.5
HV580-5R5P3B							
HV580-5R5G3B							
HV580-7R5P3B							
HV580-7R5G3B	190	305	322	208	192	φ6.0	6.5
HV580-011P3P							
HV580-011G3B							
HV580-015P3B							
HV580-015G3B							
HV580-018P3B							

#### 3) Irfa keyboard installation dimensions

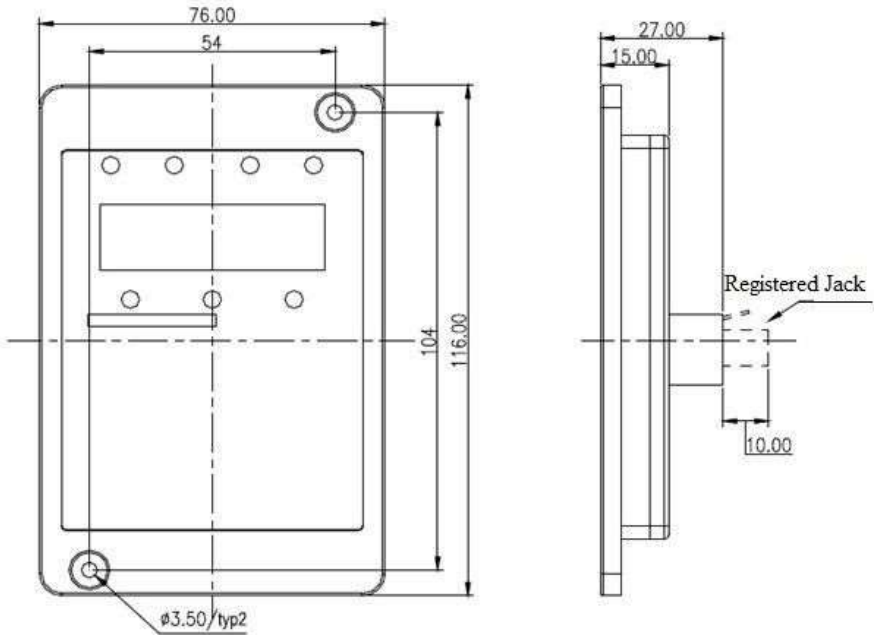

Figure 3-3 Irfpa keyboard installation dimensions

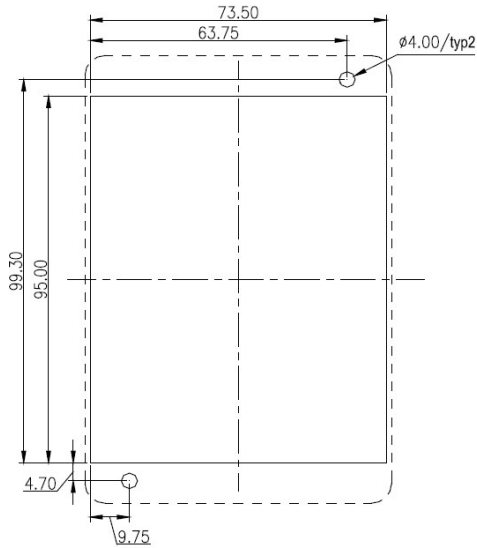

Figure 3-4 Irfpa keyboard installation hole size

## 3.2 Electrical Installation

### 3.2.1 Description of Main Circuit Terminals

Description of Main Circuit Terminals of Three-phase AC drive :

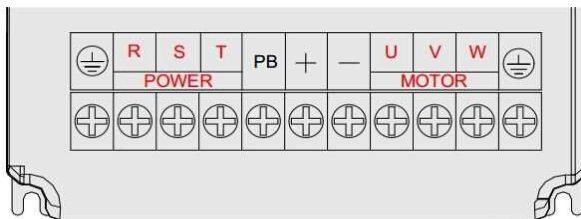



Figure 3-5 HV580 Inverter main circuit terminal distribution

### 3-2 Description of Main Circuit Terminals of Three-phase AC drive

Terminal	Name	Description
R、 S、 T	Three-phase power supply	Connect to the three-phase AC power supply

### HV580 Series Frequency Inverter

(+)、(-)	Positive and negative terminals of DC bus	Common DC bus input point Connect the external braking unit to the AC drive of 37kW and above (220 V) and 18.5 kW and above.
(+)、PB	Connecting terminals of braking resistor	Connect to the braking resistor for the AC drive of 30 kW and below (220 V) and 15 kW and below (other voltage classes).
P、(+)	Connecting terminals of external reactor	Connect to an external reactor.
U、V、W	AC drive output terminals	Connect to a three-phase motor.
	Grounding terminal	Must be grounded.

#### 3.2.2 Precautions on the Wiring

##### 1) Power input terminals L1, L2 or R, S, T :

- The cable connection on the input side of the AC drive has no phase sequence requirement.
- The specification and installation method of external power cables must comply with the local safety regulations and related IEC standards.

##### 2) DC bus terminals (+), (-):

- Terminals (+) and (-) of DC bus have residual voltage after the AC drive is switched off. After indicator CHARGE goes off, wait at least 10 minutes before touching the equipment. Otherwise, you may get electric shock.

- Connecting external braking components for the AC drive of 18.5 kW and above (220 V) and 37 kW and above (other voltage classes), do not reverse poles (+) and (-). Otherwise, it may damage the AC drive and even cause a fire.

- The cable length of the braking unit shall be no longer than 10 m. Use twisted pair wire or pair wires for parallel connection.

- Do not connect the braking resistor directly to the DC bus. Otherwise, it may damage the AC drive and even cause fire.

##### 3) Braking resistor connecting terminals (+), PB:

- 30kW and above (220 V) and 15 kW and the connecting terminals of the braking resistor are effective only for the AC configured with the built-in braking unit.

- The cable length of the braking resistor shall be less than 5 m. Otherwise, it may damage the AC drive.

##### 4) External reactor connecting terminals P, (+):

- For the AC drive of 37 kW and above (220 V) and 75 kW and above (other voltage classes), remove the

jumper bar across terminals P and (+) and install the reactor between the two terminals.

5) AC drive output terminals U, V, W:

- The specification and installation method of external power cables must comply with the local safety regulations and related IEC standards.
- The capacitor or surge absorber cannot be connected to the output side of the AC drive. Otherwise, it may cause frequent AC drive fault or even damage the AC drive.
- If the motor cable is too long, electrical resonance will be generated due to the impact of distributed capacitance. This will damage the motor insulation or generate higher leakage current, causing the AC drive to trip in over current protection. If the motor cable is greater than 100 m long, an AC output reactor must be installed close to the AC drive.

6) Terminal  PE:

- This terminal must be reliably connected to the main earthing conductor, ground wire resistance must be less than 0.1Ω. Otherwise, it may mal-function or even damage to the AC drive.
- Do not connect  the earthing terminal to the neutral conductor of the power supply.
- The impedance of the PE conductor must be able to withstand the large short circuit current that may arise when a fault occurs.
- Select the size of the PE conductor according to the following table:

Table 3-3 Grounding conductor size table

Cross-sectional Area of a Phase Conductor (S)	Min. Cross-sectional Area of Protective Conductor (Sp)
$S \leq 16\text{mm}^2$	S
$16\text{mm}^2 < S \leq 35\text{mm}^2$	16mm <sup>2</sup>
$35\text{mm}^2 < S$	S/2

- You must use a yellow/green cable as the PE conductor.

### 3.2.3 Description of Control Circuit Terminals

1) Terminal Arrangement of Control Circuit :

HV580 Series Frequency Inverter

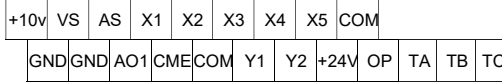

Figure 3-6 Terminal Arrangement of Control Circuit

2) Description of Control Circuit Terminals

Figure 3-4 HV580 Description of control circuit terminals

Type	Terminal	Name	Function Description
Power supply	+10V-GND	External +10 V power supply	Provide +10 V power supply to external unit. Generally, it provides power supply to external potentiometer with resistance range of 1–5 k Ω. Maximum output current: 10 mA
	+24V-COM	External +24V power Supply Applying to Over voltage Category II circuit	Provide +24 V power supply to external unit. Generally, it provides power supply to DI/DO terminals and external sensors. Maximum output current: 200 mA
	OP	Input terminal of external power supply	Connect to +24 V by default. When DI1-DI5 need to be driven by external signal, OP needs to be connected to external power supply and be disconnected from +24 V.
Analog input	VS-GND	Analog input 1	Input voltage range: 0–10 VDC Impedance: 22 kΩ
	AS-GND	Analog input2	Input range: 0–10 V DC/4–20 mA, decided by jumper J8 on the control board Impedance: 22 kΩ (voltage input), 500 Ω (current input)
Type	Terminal	Name	Function Description
Digital input	X1- OP	Digital input1	Optical coupling isolation, compatible with dual polarity input Impedance: 2.4 kΩ Voltage range for level input: 9–30 V
	X2- OP	Digital input 2	
	X3- OP	Digital input 3	
	X4- OP	Digital input 4	
	X5- OP	High-speed pulse input	Besides features of X1–X 4, it can be used for high-speed pulse input. Maximum input frequency: 100 kHz



### HV580 Series Frequency Inverter

Analog Output	AO1-GND	Analog output 1	<p>Voltage or current output is decided by jumper J5.</p> <p>Output voltage range: 0–10 V</p> <p>Output current range: 0–20 mA</p>
	Y1-CME	Digital output 1	<p>Optical coupling isolation, dual polarity open collector output</p> <p>Output voltage range: 0–24 V</p> <p>Output current range: 0–50 mA</p> <p>Note that CME and COM are internally insulated, but they are shorted by jumper externally. In this case DO1 is driven by +24 V by default. If you want to drive DO1 by external power supply, remove the jumper.</p>
Y2- COM		High-speed pulse output	<p>It is limited by P5-00 (Y2 terminal output mode selection).</p> <p>As high-speed pulse output, the maximum frequency hits 100 kHz.</p> <p>As open-collector output, its specification is the same as that of Y1</p>
Relay output	T/A-T/B	NC terminal	<p>Contact driving capacity:</p> <p>250 VAC, 3 A, COS <math>\phi</math> = 0.4</p> <p>30 VDC, 1 A</p>
	T/A-T/C	NO terminal	
Auxiliary interface	J12	Extension card interface	<p>I28-pin terminal Connect to an optional card (I/O extension card, PLC card and various bus cards)</p>
	J3	PG card	<p>Support various types of PG cards: OC, differential, UVW and resolver.</p>
	J7	External operation panel interface	<p>Connect to external operation panel.</p>

#### 3.2.4 Wiring of AC Drive Control Circuit

## HV580 Series Frequency Inverter

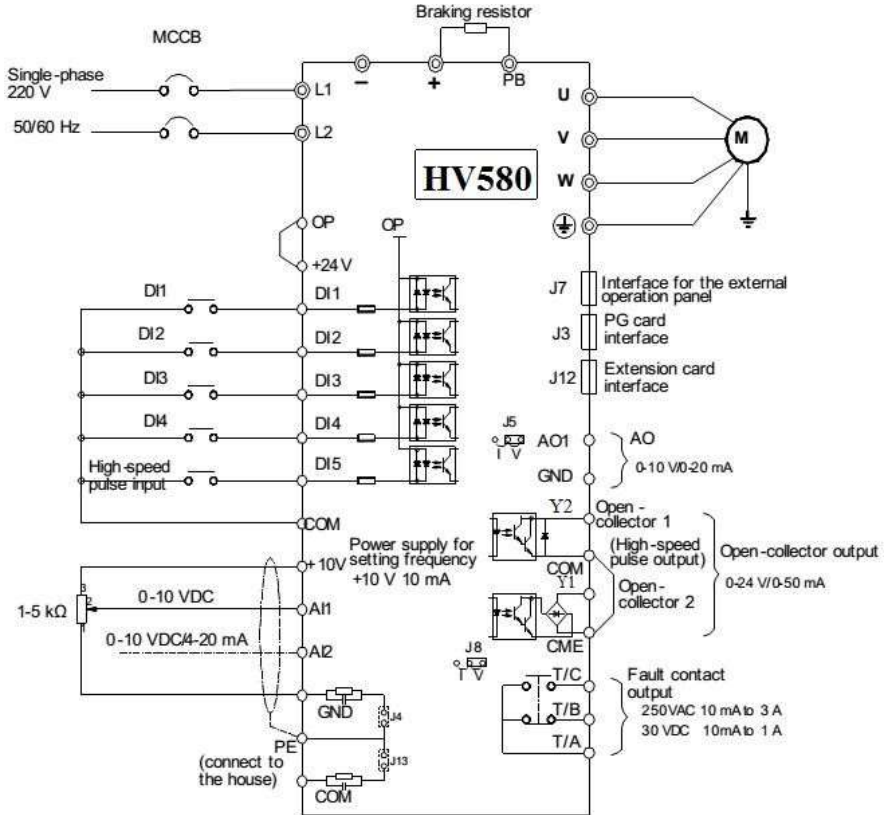

Figure 3-7 AC drives control circuit connection mode

Note: All HV580 series AC drives have the same wiring mode. The figure here shows the wiring of single-phase 220 VAC drive.

◎ indicates main circuit terminal

○ indicates control circuit terminal.

### 3.2.5 Electric Wiring of the HV580

## HV580 Series Frequency Inverter

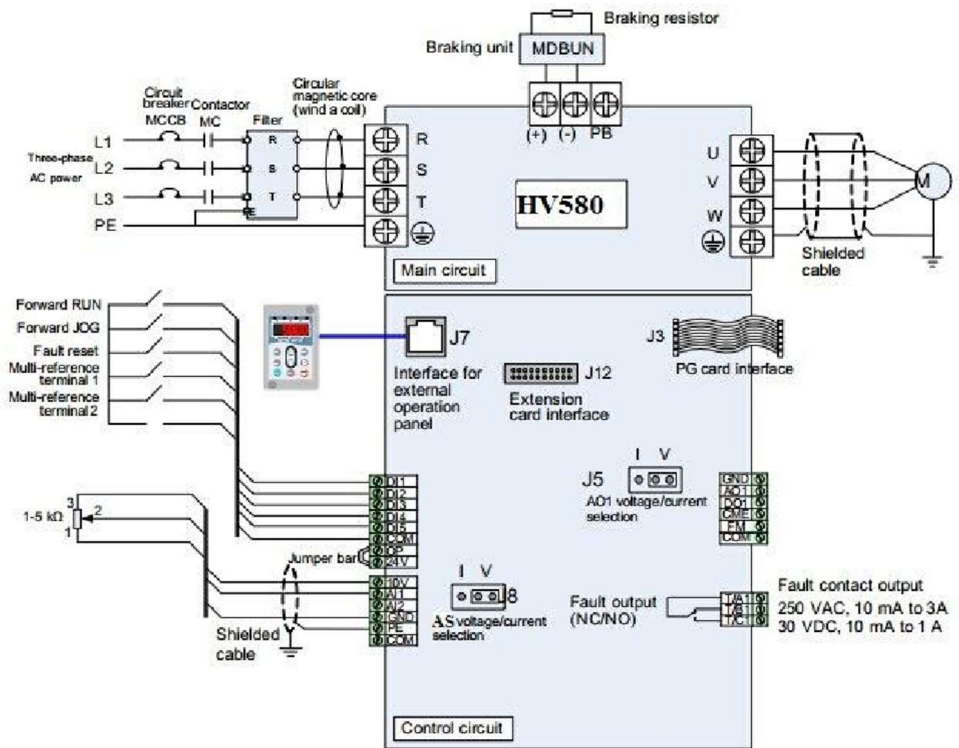

Figure 3-8 Electric wiring of the HV580

# Chapter 4 Operation, Display and Application

## Examples

### 4.1 Operation Panel

You can modify the parameters, monitor the working status and start or stop the HV580 by operating the operation panel, as shown in the following figure :

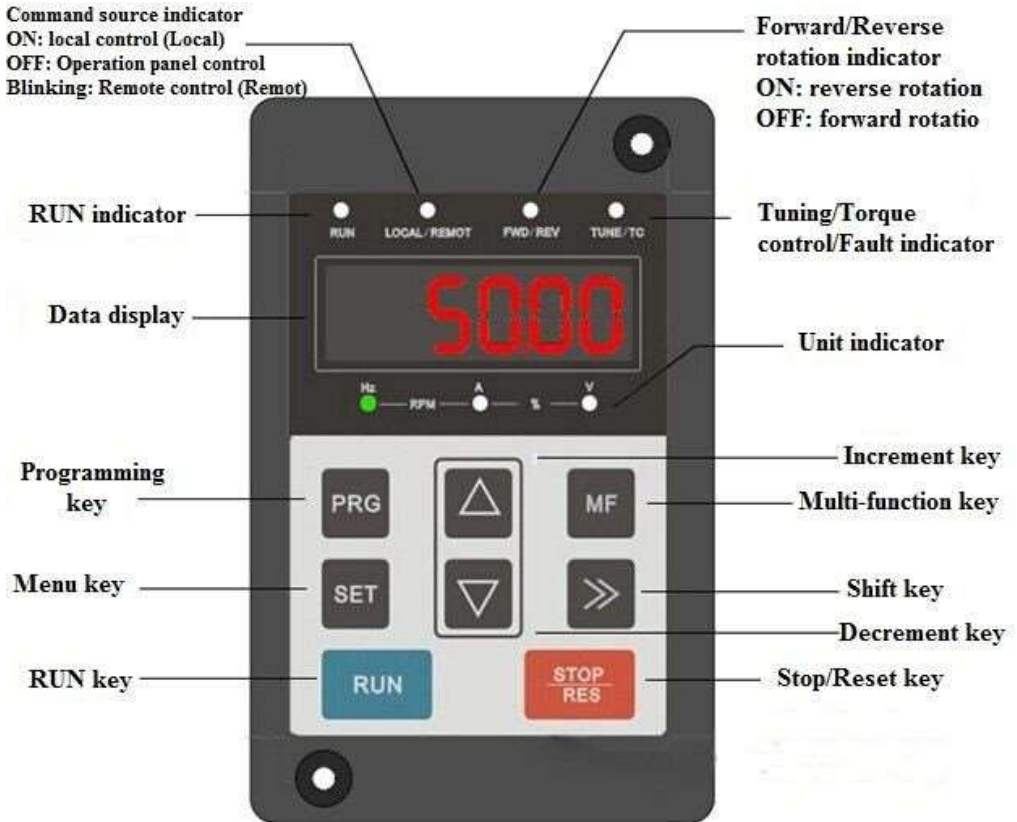

Figure 4-1 Diagram of the operation panel

**Description of Indicators:**

- RUN: ON indicates that the AC drive is in the running state, and OFF indicates that the AC drive is in the stop state.
  
- LOCAL/REMOT: It indicates whether the AC drive is operated by means of operation panel, terminals or Communication.

Figure 4-1 Figure of keyboard indicator

LOCAL/REMOT: OFF	Operation panel control
LOCAL/REMOT: ON	Terminal control
LOCAL/REMOT: blinking	Communication control

FWD/REV: ON indicates reverse rotation, and OFF indicates forward rotation.

TUNE/TC: When the indicator is ON, it indicates torque control mode. When the indicator is blinking slowly, it indicates the auto-tuning state. When the indicator is blinking quickly, it indicates the fault state.

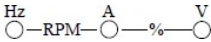



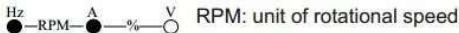
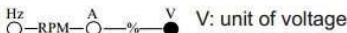
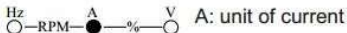
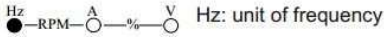





Unit indicator lamp, used to indicate the current display data unit, there are several units: (● means that the indicator is ON, and ○ means that the indicator is OFF.)



**Digital Display :**

The 5-digit LED display is able to display the set frequency, output frequency, monitoring data and fault codes.

## 4.2 Description of keys on the operation panel

Key	Name	Function
	Programming	Enter or exit Level I menu.
	Confirm	Enter the menu interfaces level by level, and confirm the parameter setting.
	Increment	Increase data or function code.
	Decrement	Decrease data or function code.
	Shift	Select the displayed parameters in turn in the stop or running state, and select the digit to be modified when modifying parameters.
	RUN	Start the AC drive in the operation panel control mode.
	Stop/Reset	Stop the AC drive when it is in the running state and perform the reset operation when it is in the fault state. The functions of this key are restricted in P7-02.
	Multifunction	Perform function switchover (such as quick switchover of command source or direction) according to the setting of P7-01.

### 4.2 Viewing and Modifying Function Codes

The operation panel of the HV580 adopts three-level menu.

The three-level menu consists of function code group (Level I), function code (Level II), and function code setting value (level III), as shown in the following figure.

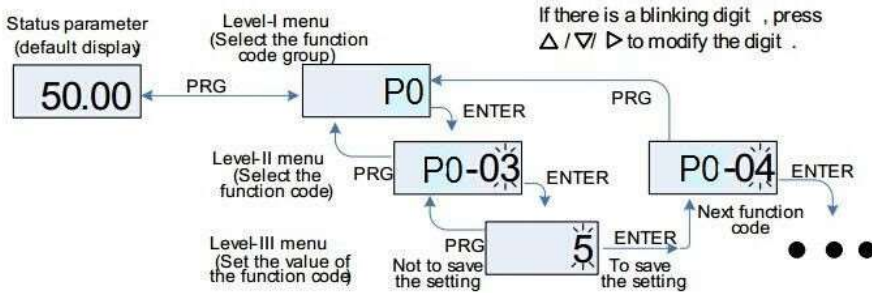
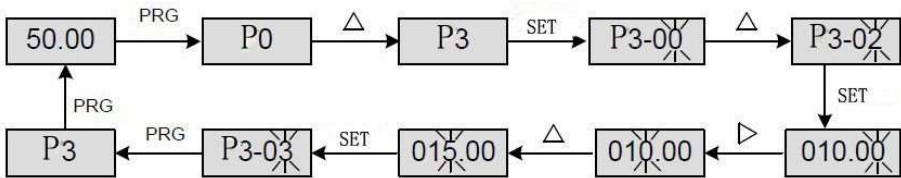

Figure 4-2 Operation procedure on the operation panel

- After you press ENTER, the system saves the parameter setting first, and then goes back to Level II menu and shifts to the next function code.
- After you press PRG, the system does not save the parameter setting, but directly returns to Level II menu and remains at the current function code.

Examples: Here is an example of changing the value of P3-02 to 15.00 Hz.



In Level III menu, if the parameter has no blinking digit, it means that the parameter cannot be modified. This may be because:

- Such a function code is only readable, such as, AC drive model, actually detected parameter and running record parameter.
- Such a function code cannot be modified in the running state and can only be changed at stop.

## Chapter 5 Function Code Table

If PP-00 is set to a non-zero number, parameter protection is enabled. You must enter the correct user password to enter the menu.

To cancel the password protection function, enter with password and set PP-00 to 0.

Group P and Group A are standard function parameters. Group C includes the monitoring function parameters.

The symbols in the function code table are described as follows:

"☆": The parameter can be modified when the AC drive is in either stop or running state.

"★": The parameter cannot be modified when the AC drive is in the running state.

"●": The parameter is the actually measured value and cannot be modified.

"\*\*\*": The parameter is factory parameter and can be set only by the manufacturer.

### 5.1 Standard Function Parameters

Function Code	Parameter Name	Setting Range	Default	Property
Group P0: Standard Function Parameters				
P0-00	GP type display	1: G type (constant torque load) 2: P type (variable torque load)	Model dependent	●
P0-01	Motor 1 control mode	0: Sensorless flux vector control (SFVC) 1: Closed-loop vector control (CLVC) 2: Voltage/Frequency (V/F) control	0	★
P0-02	Command source selection	0: Operation panel control (LED off) 1: Terminal control (LED on) 2: Communication control (LED blinking)	0	☆
P0-03	Main frequency source X selection	0: Digital setting (non-retentive at power failure) 1: Digital setting (retentive at power failure) 2: AI1 3: AI2 4: AI3 5: Pulse setting (X 5) 6: Multi-reference 7: Simple PLC 8: PID	0	★



HV580 Series Frequency Inverter

Function Code	Parameter Name	Setting Range	Default	Property
P0-04	Auxiliary frequency source Y selection	The same as P0-03 (Main frequency source X selection)	0	★
P0-05	Range of auxiliary frequency Y for X and Y operation	0: Relative to maximum frequency 1: Relative to main frequency X	0	☆
P0-06	Range of auxiliary frequency Y for X and Y operation	0% ~ 150%	100%	☆
P0-07	Frequency source selection	Unit's digit (Frequency source selection) 0: Main frequency source X 1: X and Y operation (operation relationship determined by ten's digit) 2: Switchover between X and Y 3: Switchover between X and "X and Y operation" 4: Switchover between Y and "X and Y operation" Ten's digit (X and Y operation relationship) 0: X+Y 1: X-Y 2: Maximum 3: Minimum	00	☆
P0-08	Preset frequency	0.00 to maximum frequency (valid when frequency source is digital setting)	50.00Hz	☆
P0-09	Rotation direction	0: Same direction	0	☆
P0-10	Maximum frequency	50.00Hz ~ 320.00Hz	50.00Hz	★
P0-11	Source of frequency upper limit	0: Set by F0-12 1: VS 1 2: AS 3: VS2 4: Pulse setting 5: Communication setting	0	★
P0-12	Frequency upper limit	Frequency lower limit (P0-14) to maximum frequency (P0-10)	50.00Hz	☆
P0-13	Frequency upper limit offset	0.00 Hz to maximum frequency (P0-10)	0.00Hz	☆
P0-14	Frequency lower limit	0.00 Hz to frequency upper limit (P0-12)	0.00Hz	☆

### HV580 Series Frequency Inverter

Function Code	Parameter Name	Setting Range	Default	Property
P0-15	Carrier frequency	0.5kHz ~ 16.0kHz	Model dependent	☆
P0-16	Carrier frequency adjustment with temperature	0: No 1: Yes	1	☆
P0-17	Acceleration time 1	0s ~ 65000s	Model dependent	☆
P0-18	Deceleration time 1	0s ~ 65000s	Model dependent	☆
P0-19	Acceleration/Deceleration time unit	0: 1s 1: 0.1s 2: 0.01s	1	★
P0-21	Frequency offset of auxiliary frequency source for X and Y operation	0.00 Hz to maximum frequency (P0-10)	0.00Hz	☆
P0-22	Frequency reference resolution	1: 0.1Hz 2: 0.01Hz	2	★
P0-23	Retentive of digital setting frequency upon power failure	0: Not retentive 1: Retentive	0	☆
P0-24	Motor parameter group selection	0: Motor parameter group 1 1: Motor parameter group 2 2: Motor parameter group 3 3: Motor parameter group 4	0	★
P0-25	Acceleration/Deceleration time base frequency	0: Maximum frequency (P0-10) 1: Set frequency 2: 100 Hz	0	★
P0-26	Base frequency for UP/ DOWN modification during running	0: Running frequency 1: Set frequency	0	★

HV580 Series Frequency Inverter

Function Code	Parameter Name	Setting Range	Default	Property
P0-27	Binding command source to frequency source	Unit's digit (Binding operation panel command to frequency source) 0: No binding 1: Frequency source by digital setting 2: AI1 3: AI2 4: AI3 5: Pulse setting (X 5) 6: Multi-reference 7: Simple PLC 8: PID 9: Communication setting Ten's digit (Binding terminal command to frequency source) 0–9, same as unit's digit Hundred's digit (Binding communication command to frequency source) 0–9, same as unit's digit	0000	☆
P0-28	Serial communication protocol	0: Modbus protocol 1: Profibus-DP bridge 2: CANopen bridge	0	☆
<b>Group P1: Motor 1 Parameters</b>				
P1-00	Motor type selection	0: Common asynchronous motor 1: Variable frequency asynchronous motor 2: Permanent magnetic synchronous motor	0	★
P1-01	Rated motor power	0.1kW ~ 1000.0kW	Model dependent	★
P1-02	Rated motor voltage	1V ~ 2000V	Model dependent	★
P1-03	Rated motor current	0.01–655.35A (ACdrivepower≤ 55kW) 0.1–6553.5A (ACdrivepower> 55kW)	Model dependent	★

HV580 Series Frequency Inverter

Function Code	Parameter Name	Setting Range	Default	Property
P1-04	Rated motor frequency	0.01 Hz to maximum frequency	Model dependent	★
P1-05	Rated motor rotational speed	1rpm ~ 65535rpm	Model dependent	★
P1-06	Stator resistance (asynchronous motor)	0.001–65.535Ω (ACdrivepower≤ 55 kW) 0.0001–6.5535Ω (ACdrivepower> 55 kW)	Tuned parameters	★
P1-07	Rotor resistance (asynchronous motor)	0.001–65.535Ω (ACdrivepower≤ 55 kW) 0.0001–6.5535Ω (ACdrivepower> 55 kW)	Tuned parameters	★
P1-08	Leakage inductive reactance (asynchronous motor)	0.01–655.35mH (ACdrivepower≤ 55 kW) 0.001–65.535mH (ACdrivepower> 55 kW)	Tuned parameters	★
P1-09	Mutual inductive reactance (asynchronous motor)	0.1–6553.5mH (ACdrivepower≤ 55 kW) 0.01–655.35mH (ACdrivepower> 55 kW)	Tuned parameters	★
P1-10	No-load current (asynchronous motor)	0.01toP1-03 (ACdrivepower≤ 55kW) 0.1toP1-03 (ACdrivepower> 55kW)	Tuned parameters	★
P1-16	Stator resistance (synchronous motor)	0.001–65.535Ω (ACdrivepower≤ 55 kW) 0.0001–6.5535Ω (ACdrivepower> 55 kW)	Tuned parameters	★
P1-17	Shaft D inductance (synchronous motor)	0.01–655.35mH (ACdrivepower≤ 55 kW) 0.001–65.535mH (ACdrivepower> 55 kW)	Tuned parameters	★
P1-18	Shaft Q inductance (synchronous motor)	0.01–655.35mH (ACdrivepower≤ 55 kW) 0.001–65.535mH (ACdrivepower> 55 kW)	Tuned parameters	★

HV580 Series Frequency Inverter

Function Code	Parameter Name	Setting Range	Default	Property
P1-20	Back EMF (synchronous motor)	0.1V ~ 6553.5V	Tuned parameters	★
P1-27	Encoder pulses per revolution	1 ~ 65535	1024	★
P1-28	Encoder type	0: ABZ incremental encoder 1: UVW incremental encoder 2: Resolver 3: SIN/COS encoder 4: Wire-saving UVW encoder	0	★
P1-30	A/B phase sequence of ABZ incremental encoder	0: Forward 1: Reserve	0	★
P1-31	Encoder installation angle	0.0 ~ 359.9°	0.0°	★
P1-32	U, V, W phase sequence of UVW encoder	0: Forward 1: Reverse	0	★
P1-33	UVW encoder angle offset	0.0 ~ 359.9°	0.0°	★
P1-34	Number of pole pairs of resolver	1 ~ 65535	1	★
P1-36	Encoder wire-break fault detection time	0.0s: No action 0.1–10.0s	0.0	★
P1-37	Auto-tuning selection	0: No auto-tuning 1: Asynchronous motor static auto-tuning 2: Asynchronous motor complete auto-tuning 11: Synchronous motor with-load auto-tuning 12: Synchronous motor no-load auto-tuning	0	★
Group P2: Vector Control Parameters				
P2-00	Speed loop proportional gain 1	1 ~ 100	30	☆
P2-01	Speed loop integral time 1	0.01s ~ 10.00s	0.50s	☆
P2-02	Switchover frequency 1	0.00 ~ P2-05	5.00Hz	☆
P2-03	Speed loop proportional gain 1	1 ~ 100	20	☆
P2-04	Speed loop integral time 2	0.01s ~ 10.00s	1.00s	☆
P2-05	Switchover frequency 2	P2-02 to maximum output	10.00Hz	☆
P2-06	Vector control slip gain	50% ~ 200%	100%	☆
P2-07	Time constant of speed loop filter	0.000s ~ 0.100s	0.000s	☆

HV580 Series Frequency Inverter

Function Code	Parameter Name	Setting Range	Default	Property
P2-08	Vector control over excitation gain	0 ~ 200	64	☆
P2-09	Torque upper limit source in speed control mode	0:Function Code P2-10 Setting 1: VS 2: AS 3: VS2 4: Pulse setting 5: Communication setting 6: MIN(VS,AS) 7: MAX(VS,AS) 1-7 option full scale correspond P2-10	0	☆
P2-10	Digital setting of torque upper limit in speed control mode	0.0% ~ 200.0%	150.0%	☆
P2-13	Excitation adjustment proportional gain	0 ~ 60000	2000	☆
P2-14	Excitation adjustment integral gain	0 ~ 60000	1300	☆
P2-15	Torque adjustment	0 ~ 60000	2000	☆
P2-16	Torque adjustment integral gain	0 ~ 60000	1300	☆
P2-17	Speed loop integral property	Unit's digit: integral separation 0: Disabled 1: Enabled	0	☆
P2-18	Field weakening mode of synchronous motor	0: No field weakening 1: Direct calculation 2: Automatic adjustment	1	☆
P2-19	Field weakening depth of synchronous motor	50% ~ 500%	100%	☆

HV580 Series Frequency Inverter

Function Code	Parameter Name	Setting Range	Default	Property
P2-20	Maximum field weakening current	1% ~ 300%	50%	☆
P2-21	Field weakening automatic adjustment gain	10% ~ 500%	100%	☆
P2-22	Field weakening integral multiple	2 ~ 10	2	☆
<b>Group P3: V/F Control Parameters</b>				
P3-00	V/F curve setting	0: Linear V/F 1: Multi-point V/F 2: Square V/F 3: 1.2-power V/F 4: 1.4-power V/F 6: 1.6-power V/F 8: 1.8-power V/F 9: Reserved 10: V/F complete separation 11: V/F half separation	0	★
P3-01	Torque boost	0.0% (fixed torque boost) 0.1%–30.0%	Model dependent	☆
P3-02	Cut-off frequency of torque boost	0.00 Hz to maximum output frequency	50.00Hz	★
P3-03	Multi-point V/F frequency 1	0.00Hz ~ P3-05	10.00Hz	★
P3-04	Multi-point V/F voltage 1	0.0% ~ 100.0%	28.0%	★
P3-05	Multi-point V/F frequency 2	P3-03 ~ P3-07	25.00Hz	★
P3-06	Multi-point V/F voltage 2	0.0% ~ 100.0%	55.0%	★
P3-07	Multi-point V/F frequency 3	P3-05 to rated motor frequency (P1-04)	37.00Hz	★

HV580 Series Frequency Inverter

Function Code	Parameter Name	Setting Range	Default	Property
P3-08	Multi-point V/F voltage 3	0.0% ~ 100.0%	78.0%	★
P3-09	V/F slip compensation gain	0.0% ~ 200.0%	0.0%	☆
P3-10	V/F over-excitation gain	0 ~ 200	64	☆
P3-11	V/F oscillation suppression gain	0 ~ 100	Model dependent	☆
P3-13	Voltage source for V/F separation	0: Digital setting (P3-14) 1: AI1 2: AI2 3: AI3 4: Pulse setting (X5) 5: Multi-reference 6: Simple PLC 7: PID 8: Communication setting 100.0% corresponds to the rated motor voltage	0	☆
P3-14	Voltage digital setting for V/F separation	0 V to rated motor voltage	0V	☆
P3-15	Voltage rise time of V/F separation	0.0–1000.0s It indicates the time for the voltage rising from 0 V to rated motor voltage.	0.0s	☆
Group P4 Input terminal				
P4-00	X1 function selection	0: No function	1	★
P4-01	X2 function selection	1: Forward RUN (FWD) 2: Reverse RUN (REV)	4	★
P4-02	X3 function selection	3: Three-line control 4: Forward JOG (FJOG) 5: Reverse JOG (RJOG) 6: Terminal UP	9	★



HV580 Series Frequency Inverter

P4-03	X4 function selection	7: Terminal DOWN	12	★
P4-04	X5 function selection	8: Coast to stop 9: Fault reset (RESET) 10: RUN pause 11: Normally open (NO) input of external fault 12: Multi-reference terminal 1 13: Multi-reference terminal 2 14: Multi-reference terminal 3 15: Multi-reference terminal 4 16: Terminal 1 for acceleration/ deceleration time selection 17: Terminal 2 for acceleration/ deceleration time selection 18: Frequency source switchover 19: UP and DOWN setting clear (terminal, operation panel) 20: Command source switchover terminal 1 21: Acceleration/Deceleration prohibited 22: PID pause 23: PLC status reset 24: Swing pause 25: Counter input 26: Counter reset 27: Length count input 28: Length reset	13	★
P4-10	X filter time	0. 000s~1.000s		

### HV580 Series Frequency Inverter

Function Code	Parameter Name	Setting Range	Default	Property
P4-11	Terminal command mode	0: Two-line mode 1 1: Two-line mode 2 2: Three-line mode 1 3: Three-line mode 2	0	★
P4-12	Terminal UP/DOWN rate	0.001Hz/s ~ 65.535Hz/s	1.00Hz/s	☆
P4-13	VS curve 1 minimum input	0.00V ~ P4-15	0.00V	☆
P4-14	Corresponding setting of VS curve 1 minimum input	-100.0% ~ +100.0%	0.0%	☆
P4-15	VS curve 1 maximum input	P4-13 ~ +10.00V	10.00V	☆
P4-16	Corresponding setting of VS curve 1 maximum input	-100.0% ~ +100.0%	100.0%	☆
P4-17	VS filter time	0.00s ~ 10.00s	0.10s	☆
P4-18	VS curve 2 minimum input	0.00V ~ P4-20	0.00V	☆
P4-19	Corresponding setting of VS curve 2 minimum input	-100.0% ~ +100.0%	0.0%	☆
P4-20	VS curve 2 maximum input	P4-18 ~ +10.00V	10.00V	☆
P4-21	Corresponding setting of VS curve 2 maximum input	-100.0% ~ +100.0%	100.0%	☆
P4-22	AS filter time	0.00s ~ 10.00s	0.10s	☆
P4-23	VS curve 3 minimum input	-10.00V ~ P4-25	-10.00V	☆
P4-24	VS Corresponding setting of VS curve 3 minimum input	-100.0% ~ +100.0%	-100.0%	☆
P4-25	VS curve 3 maximum input	P4-23 ~ +10.00V	10.00V	☆
P4-26	Corresponding setting of VS curve 3 maximum input	-100.0% ~ +100.0%	100.0%	☆
P4-27	VS2 filter time	0.00s ~ 10.00s	0.10s	☆
P4-28	PULSE minimum input	0.00kHz ~ P4-30	0.00kHz	☆
P4-29	Corresponding setting of pulse minimum input	-100.0% ~ 100.0%	0.0%	☆

HV580 Series Frequency Inverter

Function Code	Parameter Name	Setting Range	Default	Property
P4-30	PULSE maximum input	P4-28 ~ 100.00kHz	50.00kHz	☆
P4-31	Corresponding setting of pulse maximum input	-100.0% ~ 100.0%	100.0%	☆
P4-32	PULSE filter time	0.00s ~ 10.00s	0.10s	☆
P4-33	VS curve selection	Curve 1 (2 points, see P4-13 to P4-16) Curve 2 (2 points, see P4-18 to P4-21) Curve 3 (2 points, see P4-23 to P4-26) Curve 4 (4 points, see A6-00 to A6-07) Curve 5 (4 points, see A6-08 to A6-15) Ten's digit AS curve selection (same as VS) Hundred's digit VS2 curve selection (same as VS)	321	☆
P4-34	Setting for VS less than minimum input	Unit's digit (Setting for VS less than minimum input) 0: Minimum value 1: 0.0% Ten's digit (Setting for AS less than minimum input) 0, 1 (same as VS) Hundred's digit (Setting for VS2 less than minimum input) 0, 1 (same as VS)	000	☆

HV580 Series Frequency Inverter

Function Code	Parameter Name	Setting Range	Default	Property
P4-35	X1 delay time	0.0s ~ 3600.0s	0.0s	★
P4-36	X2 delay time	0.0s ~ 3600.0s	0.0s	★
P4-37	X3 delay time	0.0s ~ 3600.0s	0.0s	★
P4-38	X valid mode selection 1	0: High level valid 1: Low level valid Unit's digit: X1 Ten's digit: X2 Hundred's digit: X3 Thousand's digit: X4 Ten thousand's digit: X5	00000	★
P4-39	X valid mode selection 2	0: High level valid 1: Low level valid Unit's digit: X6 Ten's digit: X7 Hundred's digit: X8 Thousand's digit: X9 Ten thousand's digit: X10	00000	★
P4-40	AS input signal selection	0: Voltage signal 1: Current signal	0	★
Group P5: Output Terminals				
P5-00	Y2 terminal output mode	0: Pulse output (Y2P) 1: Pulse output (Y2R)	0	☆

HV580 Series Frequency Inverter

Function Code	Parameter Name	Setting Range	Default	Property
P5-01	Y2R function (open collector output terminal)	0: No output	0	☆
		1: AC drive running		
		2: Fault output (stop)		
		3: Frequency-level detection PDT1 output		
		4: Frequency reached		
		5: Zero-speed running (no output at stop)		
		6: Motor overload pre-warning		
		7: AC drive overload pre-warning		
		8: Set count value reached		
		9: Designated count value reached		
		10: Length reached		
		11: PLC cycle complete		
		12: Accumulative running time reached		
		13: Frequency limited		
		14: Torque limited		
		15: Ready for RUN		
		16: VS>AS		
		17: Frequency upper limit reached		
		18: Frequency lower limit reached (no output at stop)		
		19: Under voltage state output		
20: Communication setting				
P5-02	Relay function (T/A-T/B-T/C)	21: Reserved	2	☆
		22: Reserved		
		23: Zero-speed running 2 (having output at stop)		
P5-03	Extension card relay function ( P/A-P/B-P/C )	24: Accumulative power-on time reached	0	☆
		25: Frequency level detection FDT2 output		
P5-04	Y1 function selection	26: Frequency 1 reached	1	☆
P5-05	Extension card DO2 function	27: Frequency 2 reached	4	☆
		28: Current 1 reached		
		29: Current 2 reached		

HV580 Series Frequency Inverter

Function Code	Parameter Name	Setting Range	Default	Property
		30: Timing reached		
P5-06	Y2P function selection	1: Set frequency	0	☆
P5-07	AO1 function selection	2: Output current 3: Output torque (absolute value)	0	☆
P5-08	Expansion cards AO2 function selection	4: Output power 5: Output voltage 6: Pulse input 7: VS 8: AS 9: VS2 10: Length 11: Count value 12: Communication setting 13: Motor rotational speed 14: Output current ( 100.0% correspond 1000.0A) 15: Output voltage ( 100.0% correspond 1000.0V ) 16: Output torque (actual value)	1	☆
P5-09	Maximum YPY output frequency	0.01kHz~100.00 kHz	50.00kHz	☆
P5-10	AO1 offset coefficient	-100.00%~+100.00%	0.0%	☆
P5-11	A01gain	-10.00~+10.00	1.00	☆
P5-12	AO2 offset coefficient	-100.00%~+100.00%	0.00%	☆
P5-13	AO2 gain	-10.00~+10.00	1.00	☆
P5-17	Y2P output delay time	0.00S~3600.0S	0.0s	☆
P5-18	RELAY1 output delay time	0.00S~3600.0S	0.0s	☆
P5-19	RELAY2output delay time	0.00S~3600.0S	0.0s	☆

HV580 Series Frequency Inverter

P5-20	Y1 output delay time	0.00S~3600.0S	0.0s	☆
P5-21	DO2 output delay time	0.00S~3600.0S	0.0s	☆
Function Code	Parameter Name	Setting Range	Default	Property
P5-22	DO valid mode selection	0: Positive logic 1: Negative logic Unit's digit: Y2R Ten's digit: RELAY1 Hundred's digit: RELAY2 Thousand's digit: Y1 Ten thousand's digit: DO2	0.0s	☆
Group P6: Start/Stop Control				
P6.00	Start mode	0: Direct start 1: Rotational speed tracking restart	0	☆
P6.01	Rotational speed tracking mode	0: From frequency at stop 1: From zero speed	0	★
P6.02	Rotational speed tracking speed	1~100	20	☆
P6.03	Startup frequency	0.00Hz~10.00Hz	0.00Hz	☆
P6.04	Startup frequency holding time	0.0s~100.0s	0.0s	★
P6-05	Startup DC braking current/ Pre-excited current	0% ~ 100%	0%	★
P6-06	Startup DC braking time/ Pre-excited time	0.0s ~ 100.0s	0.0s	★
P6-07	Acceleration/Deceleration mode	0: Linear acceleration/deceleration 1: S-curve acceleration/deceleration A 2: S-curve acceleration/deceleration B	0	★

HV580 Series Frequency Inverter

P6-08	Time proportion of S-curve start segment	0.0% ~ (100.0%-P6-09)	30.0%	★
Function Code	Parameter Name	Setting Range	Default	Property
P6-09	Time proportion of S-curve end segment	0.0% ~ (100.0%-P6-08)	30.0%	★
P6-10	Stop mode	0: Decelerate to stop 1: Coast to stop	0	☆
P6-11	Initial frequency of stop DC braking	0.00 Hz to maximum frequency	0.00Hz	☆
P6-12	Waiting time of stop DC braking	0.0s ~ 100.0s	0.0s	☆
P6-13	Stop DC braking current	0% ~ 100%	0%	☆
P6-14	Stop DC braking time	0.0s ~ 100.0s	0.0s	☆
P6-15	Stop DC braking time	0% ~ 100%	100%	☆
Group P7: Operation Panel and Display				
P7-01	MF Key function selection	0: MF.K key disabled 1 : Switchover between operation panel control and remote command control (terminal or communication) 2 : Positive & negative switching 3: Forward JOG 4: Reverse JOG	0	★
P7-02	STOP/RESET key function	0: STOP/RESET key enabled only in operation panel control 1: STOP/RESET key enabled in any operation mode	1	☆



HV580 Series Frequency Inverter

---

Function Code	Parameter Name	Setting Range	Default	Property
P7-03	LED display running parameters 1	0000–FFFF Bit00: Running frequency 1 (Hz) Bit01: Set frequency (Hz) Bit02: Bus voltage (V) Bit03: Output voltage (V) Bit04: Output current (A) Bit05: Output power (kW) Bit06: Output torque (%) Bit07: X input status Bit08: DO output status Bit09: VS voltage (V) Bit10: AS voltage (V) Bit11: VS2 voltage (V) Bit12: Count value Bit13: Length value Bit14: Load speed display Bit15: PID setting	1F	☆

HV580 Series Frequency Inverter

P7-04	LED display running parameters 2	0000–FFFF Bit00: PID feedback Bit01: PLC stage Bit02: Pulse setting frequency(kHz) Bit03: Running frequency 2 (Hz) Bit04: Remaining running time Bit05: VS voltage before correction (V) Bit06: AS voltage before correction (V) Bit07: VS2 voltage before correction (V) Bit08: Linear speed Bit09: Current power-on time(Hour) Bit10: Current running time (Min) Bit11: Pulse setting frequency(Hz) Bit12: Communication setting value Bit13: Encoder feedback speed(Hz) Bit14: Main frequency X display(Hz) Bit15: Auxiliary frequency Y display (Hz)	0	☆
Function Code	Parameter Name	Setting Range	Default	Property
P7-05	LED display stop parameters	0000–FFFF Bit00: Set frequency (Hz) Bit01: Bus voltage (V) Bit02: X input status Bit03: DO output status Bit04: VS voltage (V) Bit05: AS voltage (V) Bit06: VS2 voltage (V) Bit07: Count value Bit08: Length value Bit09: PLC stage Bit10: Load speed Bit11: PID setting Bit12: Pulse setting frequency (kHz)	33	☆
P7-06	Load speed display	0.0001 ~ 6.5000	1.0000	☆

### HV580 Series Frequency Inverter

P7-07	Heatsink temperature of inverter module	0.0°C ~ 100.0°C	-	●
P7-08	Temporary software version	-	-	●
P7-09	Accumulative running time	0h ~ 65535h	-	●
P7-10	Product number	-	-	●
P7-11	Software version	-	-	●
P7-12	Number of decimal places for load speed display	0: 0 decimal place 1: 1 decimal place 2: 2 decimal places	1	☆
P7-13	Accumulative power-on time	0 ~ 65535 h	-	●
P7-14	Accumulative power consumption	0 ~ 65535 kwh	-	●
Group P8: Auxiliary Functions				
P8-00	JOG running frequency	0.00 Hz to maximum frequency	2.00Hz	☆
P8-01	JOG acceleration time	0.0s ~ 6500.0s	20.0s	☆
P8-02	JOG deceleration time	0.0s ~ 6500.0s	20.0s	☆
Function Code	Parameter Name	Setting Range	Default	Property
P8-03	Acceleration time 2	0.0s ~ 6500.0s	Model dependent	☆
P8-04	Deceleration time 2	0.0s ~ 6500.0s	Model dependent	☆
P8-05	Acceleration time 3	0.0s ~ 6500.0s	Model dependent	☆
P8-06	Deceleration time 3	0.0s ~ 6500.0s	Model	☆
P8-07	Acceleration time 4	0.0s ~ 6500.0s	Model	☆
P8-08	Deceleration time 4	0.0s ~ 6500.0s	Model dependent	☆
P8-09	Jump frequency 1	0.00Hz to maximum frequency	0.00Hz	☆
P8-10	Jump frequency 2	0.00Hz to maximum frequency	0.00Hz	☆
P8-11	Frequency jump amplitude	0.00Hz to maximum frequency	0.01Hz	☆
P8-12	Forward/Reverse rotation dead-zone time	0.0s ~ 3000.0s	0.0s	☆

### HV580 Series Frequency Inverter

P8-13	Reverse control	0: Enabled 1: Disabled	0	☆
P8-14	Running mode when set frequency lower than frequency lower limit	0: Run at frequency lower limit 1: Stop 2: Run at zero speed	0	☆
P8-15	Droop control	0.00Hz ~ 10.00Hz	0.00Hz	☆
P8-16	Accumulative power-on time threshold	0h ~ 65000h	0h	☆
P8-17	Accumulative running time threshold	0h ~ 65000h	0h	☆
P8-18	Startup protection	0: No 1: Yes	0	☆
P8-19	Frequency detection value(FDT1)	0.00 Hz to maximum frequency	50.00Hz	☆
P8-20	Frequency detection value(FDT1)	0.0% ~ 100.0% (FDT1 level)	5.0%	☆
Function Code	Parameter Name	Setting Range	Default	Property
P8-21	Detection range of frequency reached	0.0% ~ 100.0% (maximum frequency)	0.0%	☆
P8-22	Jump frequency during acceleration/deceleration	0: Disabled 1: Enabled	0	☆
P8-25	Frequency switchover point between acceleration time 1 and acceleration time 2	0.00 Hz to maximum frequency	0.00Hz	☆
P8-26	Frequency switchover point between deceleration time 1 and deceleration time 2	0.00 to maximum frequency	0.00Hz	☆
P8-27	Terminal JOG preferred	0: Disabled 1: Enabled	0	☆
P8-28	Frequency detection value (PDT2)	0.00 to maximum frequency	50.00Hz	☆

### HV580 Series Frequency Inverter

P8-29	Frequency detection hysteresis (PDT2)	0.0%–100.0% (PDT2 level)	5.0%	☆
P8-30	Any frequency reaching detection value 1	0.00 Hz to maximum frequency	50.00Hz	☆
P8-31	Any frequency reaching detection amplitude 1	0.0%–100.0% (maximum frequency)	0.0%	☆
P8-32	Any frequency reaching detection value 2	0.00 Hz to maximum frequency	50.00Hz	☆
P8-33	Any frequency reaching detection amplitude 2	0.0%–100.0% (maximum frequency)	0.0%	☆
P8-34	Zero current detection level	0.0%–300.0% (rated motor current)	5.0%	☆
P8-35	Zero current detection delay time	0.01s ~ 600.00s	0.10s	☆
P8-36	Output over current threshold	0.0 % (no detection) 0.1 %–300.0% (rated motor current))	200.0%	☆

Function Code	Parameter Name	Setting Range	Default	Property
P8-37	Output over current detection delay time	0.00s ~ 600.00s	0.00s	☆
P8-38	Any current reaching 1	0.0%–300.0% (rated motor current)	100.0%	☆
P8-39	Any current reaching 1 amplitude	0.0%–300.0% (rated motor current)	0.0%	☆
P8-40	Any current reaching 2	0.0%–300.0% (rated motor current)	100.0%	☆
P8-41	Any current reaching 2 amplitude	0.0%–300.0% (rated motor current)	0.0%	☆
P8-42	Timing function	0: Disabled 1: Enabled	0	☆

### HV580 Series Frequency Inverter

P8-43	Timing duration source	0: P8-44 1: AI1 2: AI2 3: AI3  (100% of analog input corresponds to the value of P8-44)	0	☆
P8-44	Timing duration	0.0Min ~ 6500.0Min	0.0Min	☆
P8-45	VS input voltage lower limit	0.00V ~ P8-46	3.10V	☆
P8-46	VS input voltage upper limit	P8-45 ~ 10.00V	6.80V	☆
P8-47	Module temperature threshold	0°C ~ 100°C	75°C	☆
P8-48	Cooling fan control	0: Fan working during running 1: Fan working continuously	0	☆
P8-49	Wakeup frequency	Dormant frequency (P8-51) to maximum frequency (P0-10)	0.00Hz	☆
P8-50	Wakeup delay time	0.0s ~ 6500.0s	0.0s	☆
P8-51	Dormant frequency	0.00 Hz to wakeup frequency (P8-49)	0.00Hz	☆
P8-52	Dormant delay time	0.0s ~ 6500.0s	0.0s	☆
P8-53	Current running time reached	0.0 ~ 6500.0 min	0.0Min	☆
P8-54	Output power correction coefficient	0.00% ~ 200.0%	100.0%	☆
Function Code	Parameter Name	Setting Range	Default	Property
<b>Group P9: Fault and Protection</b>				
P9-00	Motor overload protection selection	0: Disabled 1: Enabled	1	☆
P9-01	Motor overload protection gain	0.20 ~ 10.00	1.00	☆
P9-02	Motor overload warning coefficient	50% ~ 100%	80%	☆
P9-03	Overvoltage stall gain	0 ~ 100	0	☆
P9-04	Overvoltage stall protective voltage	120% ~ 150%	130%	☆

HV580 Series Frequency Inverter

P9-05	Overcurrent stall gain	0 ~ 100	20	☆
P9-06	Overcurrent stall protective current	100% ~ 200%	150%	☆
P9-07	Short-circuit to ground upon power-on	0: Disabled 1: Enabled	1	☆
P9-09	Fault auto reset times	0 ~ 20	0	☆
P9-10	DO action during fault auto reset	0: Not act 1: Act	0	☆
P9-11	Time interval of fault auto reset	0.1s ~ 100.0s	1.0s	☆
P9-12	Input phase loss protection/ contactor energizing protection selection	Unit's digit: Input phase loss protection Ten's digit: Contactor energizing protection 0: Disabled 1: Enabled	11	☆
P9-13	Output phase loss protection selection	0: Disabled 1: Enabled	1	☆
Function Code	Parameter Name	Setting Range	Default	Property
P9-14	1st fault type	0: No fault	—	●
P9-15	2nd fault type	1: Reserved	—	●

### HV580 Series Frequency Inverter

P9-16	3rd (latest) fault type		—	•
-------	-------------------------	--	---	---

Function Code	Parameter Name	Setting Range	Default	Property
P9-17	Frequency upon 3rd fault	—	—	•
P9-18	Current upon 3rd fault	—	—	•



### HV580 Series Frequency Inverter

P9-19	Bus voltage upon 3rd fault	—	—	●
P9-20	DI status upon 3rd fault	—	—	●
P9-21	Output terminal status upon 3rd fault	—	—	●
P9-22	AC drive status upon 3rd fault	—	—	●
P9-23	Power-on time upon 3rd fault	—	—	●
P9-24	Running time upon 3rd fault	—	—	●
P9-27	Frequency upon 2nd fault	—	—	●
P9-28	Current upon 2nd fault	—	—	●
P9-29	Bus voltage upon 2nd fault	—	—	●
P9-30	DI status upon 2nd fault	—	—	●
P9-31	Output terminal status upon 2nd fault	—	—	●
P9-32	Frequency upon 2nd fault	—	—	●
P9-33	Current upon 2nd fault	—	—	●
P9-34	Bus voltage upon 2nd fault	—	—	●
P9-37	DI status upon 1st fault	—	—	●
P9-38	Output terminal status upon 1st fault	—	—	●
P9-39	Frequency upon 1st fault	—	—	●
Function Code	Parameter Name	Setting Range	Default	Property
P9-40	Current upon 1st fault	—	—	●
P9-41	Bus voltage upon 3rd fault	—	—	●
P9-42	DI status upon 1st fault	—	—	●

HV580 Series Frequency Inverter

P9-43	Output terminal status upon 1st fault	—	—	●
P9-44	Frequency upon 1st fault	—	—	●
P9-47	Fault protection action selection 1	Unit's digit (Motor overload, Err11) 0: Coast to stop 1: Stop according to the stop mode 2: Continue to run Ten's digit (Power input phase loss, Err12) Hundred's digit (Power output phase loss, Err13) Thousand's digit (External equipment fault, Err15) Ten thousand's digit (Communication fault, Err16)	00000	☆
P9-48	Fault protection action selection 2	Unit's digit (Encoder fault, Err20) 0: Coast to stop Ten's digit (EEPROM read-write fault, Err21) 0: Coast to stop 1: Stop according to the stop mode Hundred's digit: reserved Thousand's digit (Motor overheat, Err25) Ten thousand's digit (Accumulative running time reached)	00000	☆
Function Code	Parameter Name	Setting Range	Default	Property

HV580 Series Frequency Inverter

P9-49	Fault protection action selection 3	Unit's digit (User-defined fault 1, Err27) 0: Coast to stop 1: Stop according to the stop mode 2: Continue to run Ten's digit (User-defined fault 2, Err28) 0: Coast to stop 1: Stop according to the stop mode 2: Continue to run Hundred's digit (Accumulative power-on time reached, Err29) 0: Coast to stop 1: Stop according to the stop mode 2: Continue to run Thousand's digit (Load becoming 0, Err30) 1: Coast to stop 2: Continue to run at 7% of rated motor frequency and resume to the set frequency if the load recovers	00000	☆
P9-50	Fault protection action selection 4	Unit's digit (Too large speed deviation, Err42) 0: Coast to stop 1: Stop according to the stop mode 2: Continue to run Ten's digit (Motor over-speed, Err43) Hundred's digit (Initial position fault, Err51)	00000	☆
P9-54	Frequency selection for continuing to run upon fault	0: Current running frequency 1: Set frequency 2: Frequency upper limit 3: Frequency lower limit 4: Backup frequency upon abnormality	0	☆
P9-55	Backup frequency upon abnormality	0.0% ~ 100.0% (100.0% maximum frequency P0-10)	100.0%	☆
P9-56	Type of motor temperature sensor	0: No temperature sensor 1: PT100    2: PT1000	0	☆
Function Code	Parameter Name	Setting Range	Default	Property

HV580 Series Frequency Inverter

P9-57	Motor overheat protection threshold	0°C ~ 200°C	110°C	☆
P9-58	Motor overheat warning threshold	0°C ~ 200°C	90°C	☆
P9-59	Action selection at instantaneous power failure	0: Invalid 1: Decelerate 2: Decelerate to stop	0	☆
P9-60	Action pause judging voltage at instantaneous power	80.0% ~ 100.0%	90.0%	☆
P9-61	Voltage rally judging time at instantaneous power failure	0.00s ~ 100.00s	0.50s	☆
P9-62	Action judging voltage at instantaneous power failure	60.0% ~ 100.0%(standard bus voltage)	80.0%	☆
P9-63	Protection upon load becoming 0	0: Disabled 1: Enabled	0	☆
P9-64	Detection level of load becoming 0	0.0 ~ 100.0%	10.0%	☆
P9-65	Detection time of load becoming 0	0.0 ~ 60.0s	1.0s	☆
P9-67	Over-speed detection value	0.0% ~ 50.0% (maximum frequency)	20.0%	☆
P9-68	Over-speed detection time	0.1 ~ 60.0s	5.0s	☆
P9-69	Detection value of too large speed deviation	0.0% ~ 50.0% (maximum frequency)	20.0%	☆
P9-70	Detection time of too large speed deviation	0.1 ~ 60.0s	0.0s	☆
Function Code	Parameter Name	Setting Range	Default	Property

## HV580 Series Frequency Inverter

Group PA: Process Control PID Function				
PA-00	PID setting source	0: PA-01 setting 1: VS 2: AS 3: VS2 4: PULSE setting (X5) 5: Communication setting 6: Multi-reference	0	☆
PA-01	PID digital setting	0.0% ~ 100.0%	50.0%	☆
PA-02	PID feedback source	0: VS 1: AS 2: VS2 3: VS-AS 4: PULSE setting (X5) 5: Communication setting 6: VS+AS 7: MAX( VS ,  AS ) 8: MIN( VS ,  AS )	0	☆
PA-03	PID action direction	0: Forward action 1: Reverse action	0	☆
PA-04	PID setting feedback range	0 ~ 65535	1000	☆
PA-05	Proportional gain Kp1	0.0 ~ 100.0	20.0	☆
PA-06	Integral time Ti1	0.01s ~ 10.00s	2.00s	☆
PA-07	Differential time Td1	0.000s ~ 10.000s	0.000s	☆
PA-08	Cut-off frequency of PID reverse rotation	0.00 ~ maximum frequency	2.00Hz	☆
PA-09	PID deviation limit	0.0% ~ 100.0%	0.0%	☆
PA-10	PID differential limit	0.00% ~ 100.00%	0.10%	☆
PA-11	PID setting change time	0.00 ~ 650.00s	0.00s	☆
PA-12	PID feedback filter time	0.00 ~ 60.00s	0.00s	☆
Function Code	Parameter Name	Setting Range	Default	Property

HV580 Series Frequency Inverter

PA-13	PID output filter time	0.00 ~ 60.00s	0.00s	☆
PA-14	Reserved	-	-	☆
PA-15	Proportional gain Kp2	0.0 ~ 100.0	20.0	☆
PA-16	Integral time Ti2	0.01s ~ 10.00s	2.00s	☆
PA-17	Differential time Td2	0.000s ~ 10.000s	0.000s	☆
PA-18	PID parameter switchover condition	0: No switchover 1: Switchover via DI	0	☆
PA-19	PID parameter switchover deviation 1	0.0% ~ PA-20	20.0%	☆
PA-20	PID parameter switchover deviation 2	PA-19 ~ 100.0%	80.0%	☆
PA-21	PID initial value	0.0% ~ 100.0%	0.0%	☆
PA-22	PID initial value holding time	0.00 ~ 650.00s	0.00s	☆
PA-23	Maximum deviation between two PID outputs in forward direction	0.00% ~ 100.00%	1.00%	☆
PA-24	Maximum deviation between two PID outputs in reverse direction	0.00% ~ 100.00%	1.00%	☆
PA-25	PID integral property	Unit's digit (Integral separated) 0: Invalid            1: Valid Ten's digit (Whether to stop integral operation when the output reaches the limit) 0: Continue integral operation 1: Stop integral operation	00	☆
PA-26	Detection value of PID feedback loss	0.0% : Not judging feedback loss 0.1% ~ 100.0%	0.0%	☆
PA-27	Detection time of PID feedback	0.0s ~ 20.0s	0.0s	☆
PA-28	PID operation at stop	0: No PID operation at stop 1: PID operation at stop	0	☆
Function Code	Parameter Name	Setting Range	Default	Property

### HV580 Series Frequency Inverter

Group PB: Swing Frequency, Fixed Length and Count				
Pb-00	Swing frequency setting mode	0: Relative to the central frequency 1: Relative to the maximum frequency	0	☆
Pb-01	Swing frequency amplitude	0.0% ~ 100.0%	0.0%	☆
Pb-02	Jump frequency amplitude	0.0% ~ 50.0%	0.0%	☆
Pb-03	Swing frequency cycle	0.1s ~ 3000.0s	10.0s	☆
Pb-04	Triangular wave rising time coefficient	0.1% ~ 100.0%	50.0%	☆
Pb-05	Set length	0m ~ 65535m	1000m	☆
Pb-06	Actual length	0m ~ 65535m	0m	☆
Pb-07	Number of pulses per meter	0.1 ~ 6553.5	100.0	☆
Pb-08	Set count value	1 ~ 65535	1000	☆
Pb-09	Designated count value	1 ~ 65535	1000	☆
Group PC: Multi-Reference and Simple PLC Function				
PC-00	Reference 0	-100.0% ~ 100.0%	0.0%	☆
PC-01	Reference 1	-100.0% ~ 100.0%	0.0%	☆
PC-02	Reference 2	-100.0% ~ 100.0%	0.0%	☆
PC-03	Reference 3	-100.0% ~ 100.0%	0.0%	☆
PC-04	Reference 4	-100.0% ~ 100.0%	0.0%	☆
PC-05	Reference 5	-100.0% ~ 100.0%	0.0%	☆
PC-06	Reference 6	-100.0% ~ 100.0%	0.0%	☆
PC-07	Reference 7	-100.0% ~ 100.0%	0.0%	☆
PC-08	Reference 8	-100.0% ~ 100.0%	0.0%	☆
PC-09	Reference 9	-100.0% ~ 100.0%	0.0%	☆
PC-10	Reference 10	-100.0% ~ 100.0%	0.0%	☆
PC-11	Reference 11	-100.0% ~ 100.0%	0.0%	☆
PC-12	Reference 12	-100.0% ~ 100.0%	0.0%	☆
PC-13	Reference 13	-100.0% ~ 100.0%	0.0%	☆
PC-14	Reference 14	-100.0% ~ 100.0%	0.0%	☆
PC-15	Reference 15	-100.0% ~ 100.0%	0.0%	☆
Function Code	Parameter Name	Setting Range	Default	Property

HV580 Series Frequency Inverter

PC-16	Simple PLC running mode	0: Stop after the AC drive runs one cycle 1: Keep final values after the AC drive runs one cycle 2: Repeat after the AC drive runs one cycle	0	☆
PC-17	Simple PLC retentive selection	Unit's digit (Retentive upon power failure) 0: No 1: Yes Ten's digit (Retentive upon stop) 0: No 1: Yes	00	☆
PC-18	Running time of simple PLC reference 0	0.0s(h) ~ 6553.5s(h)	0.0s(h)	☆
PC-19	Acceleration/deceleration time of simple PLC reference 0	0 ~ 3	0	☆
PC-20	Running time of simple PLC reference 1	0.0s(h) ~ 6553.5s(h)	0.0s(h)	☆
PC-21	Acceleration/deceleration time of simple PLC reference 1	0 ~ 3	0	☆
PC-22	Running time of simple PLC reference 2	0.0s(h) ~ 6553.5s(h)	0s(h)	☆
PC-23	Acceleration/deceleration time of simple PLC reference 2	0 ~ 3	0	☆
PC-24	Running time of simple PLC reference 3	0.0s(h) ~ 6553.5s(h)	0.0s(h)	☆
PC-25	Acceleration/deceleration time of simple PLC reference 3	0 ~ 3	0	☆
PC-26	Running time of simple PLC reference 4	0.0s(h) ~ 6553.5s(h)	0.0s(h)	☆
Function Code	Parameter Name	Setting Range	Default	Property



HV580 Series Frequency Inverter

PC-27	Acceleration/deceleration time of simple PLC reference 4	0 ~ 3	0	☆
PC-28	Running time of simple PLC reference 5	0.0s(h) ~ 6553.5s(h)	0.0s(h)	☆
PC-29	Acceleration/deceleration time of simple PLC reference 5	0 ~ 3	0	☆
PC-30	Running time of simple PLC reference 6	0.0s(h) ~ 6553.5s(h)	0.0s(h)	☆
PC-31	Acceleration/deceleration time of simple PLC reference 6	0 ~ 3	0	☆
PC-32	Running time of simple PLC reference 7	0.0s(h) ~ 6553.5s(h)	0.0s(h)	☆
PC-33	Acceleration/deceleration time of simple PLC reference 7	0 ~ 3	0	☆
PC-34	Running time of simple PLC reference 8	0.0s(h) ~ 6553.5s(h)	0.0s(h)	☆
PC-35	Acceleration/deceleration time of simple PLC reference 8	0 ~ 3	0	☆
PC-36	Running time of simple PLC reference 9	0.0s(h) ~ 6553.5s(h)	0.0s(h)	☆
PC-37	Acceleration/deceleration time of simple PLC reference 9	0 ~ 3	0	☆
PC-38	Running time of simple PLC reference 10	0.0s(h) ~ 6553.5s(h)	0.0s(h)	☆
PC-39	Acceleration/deceleration time of simple PLC reference 10	0 ~ 3	0	☆
PC-40	Running time of simple PLC reference 11	0.0s(h) ~ 6553.5s(h)	0.0s(h)	☆
PC-41	Acceleration/deceleration time of simple PLC reference 11	0 ~ 3	0	☆
Function Code	Parameter Name	Setting Range	Default	Property

HV580 Series Frequency Inverter

PC-42	Running time of simple PLC reference 12	0.0s(h) ~ 6553.5s(h)	0.0s(h)	☆
PC-43	Acceleration/deceleration time of simple PLC reference 12	0 ~ 3	0	☆
PC-44	Running time of simple PLC reference 13	0.0s(h) ~ 6553.5s(h)	0.0s(h)	☆
PC-45	Acceleration/deceleration time of simple PLC reference 13	0 ~ 3	0	☆
PC-46	Running time of simple PLC reference 14	0.0s(h) ~ 6553.5s(h)	0.0s(h)	☆
PC-47	Acceleration/deceleration time of simple PLC reference 14	0 ~ 3	0	☆
PC-48	Running time of simple PLC reference 15	0.0s(h) ~ 6553.5s(h)	0.0s(h)	☆
PC-49	Acceleration/deceleration time of simple PLC reference 15	0 ~ 3	0	☆
PC-50	Time unit of simple PLC running	0: s (second) 1: h (hour)	0	☆
PC-51	Reference 0 source	0: Set by PC-00 1: VS 2: AS 3: VS2 4: PULSE setting 5: PID 6: Set by preset frequency (P0-08), modified via terminal UP/DOWN	0	☆

HV580 Series Frequency Inverter

Function Code	Parameter Name	Setting Range	Default	Property
Group Pd: Communication Parameters				
Pd-00	Baud rate	Unit's digit: MODBUS 0: 300BPS 1: 600BPS 2: 1200BPS 3: 2400BPS 4: 4800BPS 5: 9600BPS 6: 19200BPS 7: 38400BPS 8: 57600BPS 9: 115200BPS Ten's digit: Profibus-DP 0: 115200BPs 1: 208300BPs 2: 256000BPs 3: 512000Bps Hundred's digit (reserved) Thousand's digit: CANlink baud rate 0: 20 1: 50 2: 100 3: 125 4: 250 5: 500 6: 1M	6005	☆
Pd-01	MODBUS Data format	0: No check, data format (8-N-2) 1: Even parity check, data format (8-E-1) 2: Odd parity check, data format (8-O-1) 3: No check, data format (8-N-1) (Valid for MODBUS)	0	☆

HV580 Series Frequency Inverter

Function Code	Parameter Name	Setting Range	Default	Property
Pd-02	Local address	0: Broadcast address 1 ~ 247	1	☆
Pd-03	MODBUS Response delay	0 ~ 20ms (Valid for MODBUS)	2	☆
Pd-04	Communication timeout	0.0: invalid 0.1 ~ 60.0s (Valid for MODBUS, Profibus-DP, and CANopen)	0.0	☆
Pd-05	Modbus protocol selection and PROFIBUS-DP data format	Unit's digit: MODBUS 0: Non-standard Modbus protocol 1: Standard Modbus protocol Ten's digit: Profibus-DP 0: PPO1 format 1: PPO2 format 2: PPO3 format 3: PPO5 format	30	☆
Pd-06	Communication reading current resolution	0: 0.01A 1: 0.1A	0	☆
Pd-08	Canlink communication timeout time	0.0s: Invalid 0.1~60.0s	0	☆
Group PP: Function Code Management				
PP-00	User password	0~65535	0	☆
PP-01	Restore default settings	0: No operation 01: Restore factory settings except motor parameters 02: Clear records 04: Restore user backup parameters 501: Back up current user parameters	0	★

HV580 Series Frequency Inverter

Function Code	Parameter Name	Setting Range	Default	Property
PP-02	AC drive parameter display property	Unit's digit (Group U display selection) 0: Not display 1: Display Ten's digit (Group A display selection) 0: Not display 1: Display	11	★
PP-03	Individualized parameter display property	Unit's digit (User-defined parameter display selection) 0: Not display 1: Display Ten's digit (User-modified parameter display selection) 0: Not display 1: Display	00	☆
PP-04	Parameter modification property	0: Modifiable 1: Not modifiable	0	☆
<b>Group A0: Torque Control and Restricting Parameters</b>				
A0-00	Speed/Torque control selection	0: Speed control 1: Torque control	0	★
A0-01	Torque setting source in torque control	0: Digital setting 1(A0-03) 1: VS 2: AS 3: VS2 4: PULSE setting 5: Communication setting 6: MIN(VS,AS) 7: MAX(VS,AS) Full range of values 1–7 corresponds to the digital setting of A0-03	0	★

### HV580 Series Frequency Inverter

Function Code	Parameter Name	Setting Range	Default	Property
A0-03	Torque digital setting in torque control	-200.0% ~ 200.0%	150.0%	☆
A0-05	Forward maximum frequency in torque control	0.00Hz ~maximum frequency	50.00Hz	☆
A0-06	Reverse maximum frequency in torque control	0.00Hz ~maximum frequency	50.00Hz	☆
A0-07	Acceleration time in torque control	0.00s ~ 65000s	0.00s	☆
A0-08	Deceleration time in torque control	0.00s ~ 65000s	0.00s	☆

Table 5-2 Monitoring Parameters

Function Code	Parameter Name	Min. Unit	Communication Address
Group C: Standard Monitoring Parameters			
C-00	Running frequency (Hz)	0.01Hz	7000H
C-01	Set frequency (Hz)	0.01Hz	7001H
C-02	Bus voltage (V)	0.1V	7002H
C-03	Output voltage (V)	1V	7003H
C-04	Output current (A)	0.01A	7004H
C-05	Output power (kW)	0.1kW	7005H
C-06	Output torque (%)	0.1%	7006H
C-07	X DI state	1	7007H
C-08	DO DO state	1	7008H
C-09	VS voltage (V)	0.01V	7009H
C-10	AS voltage (V)/ current (mA)	0.01V/0.01mA	700AH
C-11	VS2 voltage (V)	0.01V	700BH
C-12	Count value	1	700CH
C-13	Length value	1	700DH
C-14	Load speed	1	700EH
C-15	PID setting	1	700FH
C-16	PID feedback	1	7010H

### HV580 Series Frequency Inverter

Function Code	Parameter Name	Min. Unit	Communication Address
C-17	PLC stage	1	7011H
C-18	Input pulse frequency (Hz)	0.01kHz	7012H
C-19	Feedback speed (Hz)	0.01Hz	7013H
C-20	Remaining running time	0.1Min	7014H
C-21	VS voltage before correction	0.001V	7015H
C-22	AS voltage (V) / current (mA) before correction	0.001V/0.01mA	7016H
C-23	VS2 voltage before correction	0.001V	7017H
C-24	Linear speed	1m/Min	7018H
C-25	Accumulative power-on time	1Min	7019H
C-26	Accumulative running time	0.1Min	701AH
C-27	PULSE input frequency	1Hz	701BH
C-28	Communication setting value	0.01%	701CH
C-29	Encoder feedback speed	0.01Hz	701DH
C-30	Main frequency X	0.01Hz	701EH
C-31	Auxiliary frequency Y	0.01Hz	701FH
C-32	Viewing any register address value	1	7020H
C-33	Synchronous motor rotor position	0.1°	7021H
C-34	Motor temperature	1°C	7022H
C-35	Target torque (%)	0.1%	7023H
C-36	Resolver position	1	7024H
C-37	Power factor angle	0.1°	7025H
C-38	ABZ position	1	7026H
C-39	Target voltage upon V/F separation	1V	7027H
C-40	Output voltage upon V/F separation	1V	7028H
C-41	X DI state visual display	1	7029H
C-42	DO state visual display	1	702AH
C-43	X DI function state visual display 1 (function 01-40)	1	702BH
C-44	X DI function state visual display 2 (function 41- 80)	1	702CH
C-45	Fault information	1	702DH
C-58	Phase Z counting	1	703AH
C-59	Current set frequency (%)	0.01%	703BH
C-60	Current running frequency (%)	0.01%	703CH
C-61	AC drive running state	1	703DH
C-62	Current fault code	1	703EH
C-63	Reserved	-	-
C-64	Reserved	-	-
C-65	Torque upper limit	0.1%	7041H

## Chapter 6 Description of Function Codes

### Group P0: Basic Parameters

P0-00	GP type display		Default	Model dependent
	Setting Range	1	G type (constant torque load)	
		2	P type (variable torque load e.g. fan and pump)	

This parameter is used to display the delivered model and cannot be modified

1: Applicable to constant torque load with rated parameters specified

2: Applicable to variable torque load (fan and pump) with rated parameters specified

P0-01	Motor 1 control mode		Default	0
	Setting Range	0	Sensor less flux vector control (SVC)	
		1	Closed-loop vector control (FVC)	
		2	Voltage/Frequency (V/F) control	

0: Sensor less flux vector control (SVC)

It indicates open-loop vector control, and is applicable to high-performance control applications such as machine tool, centrifuge, wire drawing machine and injection moulding machine. One AC drive can operate only one motor.

1: Closed-loop vector control (CLVC)

It is applicable to high-accuracy speed control or torque control applications such as high-speed paper making machine, crane and elevator. One AC drive can operate only one motor. An encoder must be installed at the motor side, and a PG card matching the encoder must be installed at the AC drive side.

2: Voltage/Frequency (V/F) control

It is applicable to applications with low load requirements or applications where one AC drive operates multiple motors, such as fan and pump.

**Note:** If vector control is used, motor auto-tuning must be performed because the advantages of vector control can only be utilized after correct motor parameters are obtained. Better performance can be achieved by adjusting speed regulator parameters in group P2 (or groups A2, A3, and A4 respectively for motor 2, 3, and 4). For the permanent magnetic synchronous motor (PMSM), the HV580 does not support SVC. FVC is used generally. In some low-power motor applications, you can also use V/F.



## HV580 Series Frequency Inverter

P0-02	Command source selection		Default	0
	Setting Range	0	Operation panel control (LED off)	
		1	Terminal control (LED on)	
		2	Communication control (LED blinking)	

It is used to determine the input channel of the AC drive control commands, such as run, stop, forward rotation, reverse rotation and jog operation.

0 : Operation panel control channel ("LOCAL/REMOT" indicator off)

Commands are given by pressing keys "RUN" and "STOP/RES" on the operation panel

1 : Terminal control ("LOCAL /REMOT" indicator on)

Commands are given by means of multifunctional input terminals with functions such as FWD, REV, JOGF, and JOGR.

2 : Communication control channel ("LOCAL/REMOT" indicator blinking)

Commands are given from host computer. If this parameter is set to 2, a communication card (Modbus RTU, PROFIBUS-DP card, CANlink card, user programmable card or CANopen card) must be installed

Related to the communication function parameters, please see the "PD group communication parameters" instructions, and reference the corresponding communication card, the appendix of this manual contains brief explanation of communication card.

P0-03	Main frequency source X selection		Default	0
	Setting Range	0	Digital setting (Preset frequency P0-08, UP/DOWN revisable, non-retentive at power failure)	
		1	Digital setting (Preset frequency P0-08, UP/DOWN revisable, retentive at power failure)	
		2	VS	
		3	AS	
		4	VS2	
		5	Pulse setting (X5)	
		6	Multi-reference	
		7	PLC	
		8	PID	
		9	Communication setting	

It is used to select the setting channel of the main frequency. You can set the main frequency in the following 10 channels:

0: Digital setting (non-retentive at power failure)

## HV580 Series Frequency Inverter

---

The initial value of the set frequency is the value of P0-08 (Preset frequency). You can change the set frequency by pressing ▲ and ▼ on the operation panel (or using the UP/DOWN functions of input terminals).

When the AC drive is powered on again after power failure, the set frequency reverts to the value of P0-08.

### 1: Digital setting (retentive at power failure)

The initial value of the set frequency is the value of P0-08 (Preset frequency). You can change the set frequency by pressing keys ▲ and ▼ on the operation panel (or using the UP/DOWN functions of input terminals).

When the AC drive is powered on again after power failure, the set frequency is the value memorized at the moment of the last power failure.

Note that P0-23 (Retentive of digital setting frequency upon power failure) determines whether the set frequency is memorized or cleared when the AC drive stops. It is related to stop rather than power failure.

### 2: VS

### 3: AS

### 4: VS2

The frequency is set by analog input. The HV580 control board provides two analog input terminals (VS, AS). Another AI terminal (VS2) is provided by the I/O extension card.

VS is 0V~10V voltage input, AS can be 0V~10V voltage input, or 4mA ~ 20mA current input, it is determined by jumper J8, VS2 is -10V~10V voltage input.

The HV580 provides five curves indicating the mapping relationship between the input voltages of VS, AS and VS2 and the target frequency, three of which are linear (point - point) correspondence and two of which are four-point correspondence curves. You can set the curves by using function codes P4-13 to P4-27 and function codes in group A6, and select curves for VS~VS2 in P4-33. For the five curves specific corresponding relations, please refer to the P4, A6 group function code.

### 5: Pulse setting (X5)

The frequency is set by X5 (high-speed pulse). The signal specification of pulse setting is 9–30 V (voltage range) and 0–100 kHz (frequency range). Input pulse can only be given from multifunctional input terminals X5.

The relation between X5 terminal input pulse frequency and the corresponding set, is designed through the P4-28, the corresponding relation of two points is straight line corresponding relation. The corresponding value 100% of pulse setting corresponds to the value of P0-10 (Maximum frequency).

### 6: Multi-reference

In multi-reference mode, combinations of different DI terminal states correspond to different set frequencies.

The HV580 supports a maximum of 16 speeds implemented by 16 state combinations of four DI terminals

## HV580 Series Frequency Inverter

(allocated with functions 12 to 15) in Group PC. The multiple references indicate percentages of the value of P0-10 (Maximum frequency).

If a DI terminal is used for the multi-reference function, you need to perform related setting in group P4.

### 7: Simple PLC

When the simple programmable logic controller (PLC) mode is used as the frequency source, the running frequency of the AC drive can be switched over among the 16 frequency references. You can set the holding time and acceleration/deceleration time of the 16 frequency references. For more details, please refer to the descriptions of Group PC.

### 8: PID

The output of PID control is used as the running frequency. PID control is generally used in on-site closed-loop control, such as constant pressure closed-loop control and constant tension closed-loop control.

When applying PID as the frequency source, you need to set parameters of PID function in group PA.

### 9: Communication setting

The frequency is set by means of communication.

The HV580 supports four host computer communication protocols: Modbus, PROFIBUS-DP, CANopen and CANlink. They cannot be used simultaneously.

If the communication mode is used, a communication card must be installed. The HV580 provides four optional communication cards and you can select one based on actual requirements. If the communication protocol is Modbus, PROFIBUS-DP or CANopen, the corresponding serial communication protocol needs to be selected based on the setting of P0-28.

P0-04	Auxiliary frequency source Y selection		Default	0
	Setting Range	0	Digital setting (preset frequency P0-08, UP/DOWN revisable, non-retentive power failure)	
		1	Digital setting (preset frequency P0-08, UP/DOWN revisable, retentive at power failure)	
		2	VS	
		3	AS	
		4	VS2	
		5	Pulse setting (X5)	
		6	Multi-reference	
		7	PLC	
		8	PID	
		9	Communication setting	

When used as an independent frequency input channel (frequency source switched over from X to Y), the

## HV580 Series Frequency Inverter

auxiliary frequency source Y is used in the same way as the main frequency source X (refer to P0-03).

When the auxiliary frequency source is used for operation (frequency source is "X and Y operation"), pay attention to the following aspects:

1. If the auxiliary frequency source Y is digital setting, the preset frequency (P0-08) does not take effect. You can directly adjust the set main frequency by pressing keys ▲ and ▼ on the operation panel (or using the UP/DOWN function of input terminals).
2. If the auxiliary frequency source is analog input (VS, AS and VS2) or pulse setting, 100% of the input corresponds to the range of the auxiliary frequency Y (set in P0-05 and P0-06).
3. If the auxiliary frequency source is pulse setting, it is similar to analog input.

Note: The main frequency source X and auxiliary frequency source Y must not use the same channel. That is, P0-03 and P0-04 cannot be set to the same value.

P0-05	Range of auxiliary frequency Y for X and Y operation		Default	0
	Setting Range	0	Relative to maximum frequency	
1		Relative to main frequency X		
P0-06	Range of auxiliary frequency Y for X and Y operation		Default	0
	Setting Range		0% ~ 150%	

If X and Y operation is used, P0-05 and P0-06 are used to set the adjustment range of the auxiliary frequency source. You can set the auxiliary frequency to be relative to either maximum frequency or main frequency X. If relative to main frequency X, the setting range of the auxiliary frequency Y varies according to the main frequency X.

P0-07	Frequency source selection		Default	0
	Setting Range	Unit's digit	Frequency source selection	
		0	Main frequency source X	
		1	X and Y operation (operation relationship determined by ten's digit)	
		2	Switchover between X and Y	
		3	Switchover between X and "X and Y operation"	
		4	Switchover between Y and "X and Y operation"	
		Ten's digit	X and Y operation relationship	
		0	X + Y	
		1	X - Y	
		2	Maximum	
3	Minimum			

It is used to select the frequency setting channel. If the frequency source involves X and Y operation, you can

## HV580 Series Frequency Inverter

---

set the frequency offset in P0-21 for superposition to the X and Y operation result, flexibly satisfying various requirements.

Unit's digit: Frequency source selection

0: Main frequency source X

Main frequency source X as target frequency

1: X and Y operation

Main and auxiliary operation result as the target frequency, main and auxiliary operation relationship see the description of ten digits.

2: Main frequency source X and auxiliary frequency Y switchover

When the multi-function input terminals function 18 (frequency switch) is invalid, the main frequency X as the target frequency.

When the multi-function input terminals function 18 (frequency switch) is valid, the auxiliary frequency Y as the target frequency.

3: The main frequency source X switchover with the main and auxiliary operation result.

When the multi-function input terminals function 18 (frequency switch) is invalid, the main frequency X as the target frequency.

When the multi-function input terminals function 18 (frequency switch) is valid, the main and auxiliary operation result as the target frequency.

4: The auxiliary frequency source Y switchover with the main and auxiliary operation result.

When the multi-function input terminals function 18 (frequency switch) is invalid, the auxiliary frequency Y as the target frequency.

When the multi-function input terminals function 18 (frequency switch) is valid, the main and auxiliary operation result as the target frequency.

Ten digits: Frequency source main and auxiliary operation relations.

0: X+Y

The target frequency is the sum of main frequency X and auxiliary frequency Y.

1: X-Y

The target frequency is the difference between main frequency X and auxiliary frequency Y.

2: MAX

The target frequency is the largest absolute value of main frequency X and auxiliary frequency Y.

3: MIN

The target frequency is the least absolute value of main frequency X and auxiliary frequency Y.

In addition, when the frequency source selection is X and Y, offset frequency can be set by P0-21, offset frequency, superimposed on the advocate complementary operation results in a flexible response to various needs.

P0-08	Preset frequency	Default	50.00Hz
	Setting Range	0.00~maximum frequency (valid when frequency source is digital setting)	

If the frequency source is digital setting or terminal UP/DOWN, the value of this parameter is the initial frequency of the AC drive (digital setting)

P0-09	Rotation direction	Default	0
	Setting Range	0	Same direction
		1	Reverse direction

You can change the rotation direction of the motor just by modifying this parameter without changing the motor wiring. Modifying this parameter is equivalent to exchanging any two of the motor's U, V, W wires.

**Note:** The motor will resume running in the original direction after parameter initialization. Do not use this function in applications where changing the rotating direction of the motor is prohibited after system commissioning is complete.

P0-10	Maximum frequency	Default	50.00 Hz
	Setting Range	50.00Hz ~ 320.00Hz	

When the frequency source is AI, pulse setting (X5), or multi-reference, 100% of the input corresponds to the value of this parameter.

The output frequency of the HV580 can reach up to 3200 Hz. To take both frequency reference resolution and frequency input range into consideration, you can set the number of decimal places for frequency reference in P0-22.

If P0-22 is set to 1, the frequency reference resolution is 0.1 Hz. In this case, the setting range of P0-10 is 50.0 to 3200.0 Hz.

If P0-22 is set to 2, the frequency reference resolution is 0.01 Hz. In this case, the setting range of P0-10 is 50.00 to 3200.00 Hz.

P0-11	Source of frequency upper limit	Default	0
	Setting Range	0	Set by P0-12
		1	VS
		2	AS
		3	VS2
		4	PULSE setting (X5)
		5	Communication setting

## HV580 Series Frequency Inverter

It is used to set the source of the frequency upper limit, including digital setting (P0-12), AI, pulse setting or communication setting. If the frequency upper limit is set by means of analog input, the analog input setting is 100% corresponding to P0-12.

For example, to avoid runaway in torque control mode in winding application, you can set the frequency upper limit by means of analog input. When the AC drive reaches the upper limit, it will continue to run at this speed.

P0-12	Frequency upper limit	Default	50.00Hz
	Setting Range	Frequency lower limit P0-14 ~maximum frequency P0-10	
P0-13	Frequency upper limit offset	Default	0.00Hz
	Setting Range	0.00Hz ~maximum frequency P0-10	

If the source of the frequency upper limit is analog input or pulse setting, the final frequency upper limit is obtained by adding the offset in this parameter to the frequency upper limit set in P0-11

P0-14	Frequency lower limit	Default	0.00Hz
	Setting Range	0.00Hz ~frequency upper limit P0-12	

If the frequency reference is lower than the value of this parameter, the AC drive can stop, run at the frequency lower limit, or run at zero speed, determined by P8-14.

P0-15	Carrier frequency	Default	Model dependent
	Setting Range	0.5kHz ~ 16.0kHz	

It is used to adjust the carrier frequency of the AC drive, helping to reduce the motor noise, avoiding the resonance of the mechanical system, and reducing the leakage current to the earth and interference generated by the AC drive.

If the carrier frequency is low, output current has high harmonics, and the power loss and temperature rise of the motor increase.

If the carrier frequency is high, power loss and temperature rise of the motor declines.

However, the AC drive has an increase in power loss, temperature rise and interference.

Adjusting the carrier frequency will exert influences on the aspects listed in the following table:

Carrier frequency	Low	→	High
Motor noise	Large	→	Small
Output current waveform	Bad	→	Good
Motor temperature rise	High	→	Low
AC drive temperature rise	Low	→	High
Leakage current	Small	→	Large
External radiation interference	Small	→	Large

## HV580 Series Frequency Inverter

The factory setting of carrier frequency varies with the AC drive power. If you need to modify the carrier frequency, note that if the set carrier frequency is higher than factory setting, it will lead to an increase in temperature rise of the AC drive's heatsink. In this case, you need to de-rate the AC drive. Otherwise, the AC drive may overheat and alarm.

P0-16	Carrier frequency adjustment with temperature	Default	1
	Setting Range	0: No    1: Yes	

It is used to set whether the carrier frequency is adjusted based on the temperature. The AC drive automatically reduces the carrier frequency when detecting that the heatsink temperature is high. The AC drive resumes the carrier frequency to the set value when the heatsink temperature becomes normal. This function reduces the overheat alarms.

P0-17	Acceleration time 1	Default	Model dependent
	Setting Range	0.00s ~ 650.00s (P0-19=2) 0.0s ~ 6500.0s (P0-19=1)	
P0-18	Deceleration time 1	Default	Model dependent
	Setting Range	0.00s ~ 650.00s (P0-19=2) 0.0s ~ 6500.0s (P0-19=1)	

Acceleration time indicates the time required by the AC drive to accelerate from 0 Hz to

"Acceleration/Deceleration base frequency" (P0-25), that is,  $t_1$  in Figure 6-1.

Deceleration time indicates the time required by the AC drive to decelerate from

"Acceleration/Deceleration base frequency" (P0-25) to 0 Hz, that is,  $t_2$  in Figure 6-1.

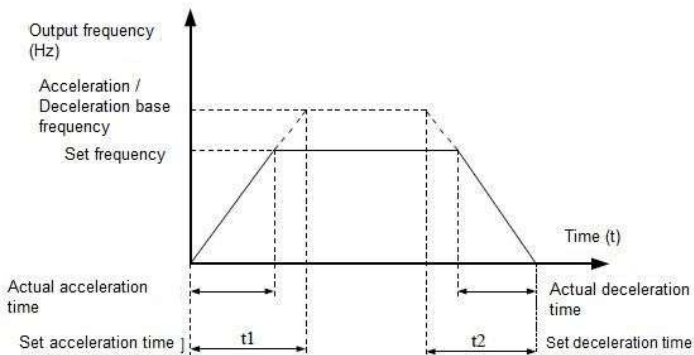

Figure 6-1 Acceleration / Deceleration time



## HV580 Series Frequency Inverter

The HV580 provides totally four groups of acceleration/deceleration time for selection. You can perform switchover by using a DI terminal.

Group 1: P0-17, P0-18

Group 2: P8-03, P8-04

Group 3: P8-05, P8-06

Group 4: P8-07, P8-08

P0-19	Acceleration/Deceleration time unit	Default	1
	Setting Range	0	1s
		1	0.1s
	2	0.01s	

To satisfy requirements of different applications, the HV580 provides three acceleration/deceleration time units, 1s, 0.1s and 0.01s.

Note:

Modifying this parameter will make the displayed decimal places change and corresponding acceleration/deceleration time also change.

P0-21	Frequency offset of auxiliary frequency source for X and Y operation	Default	0.00Hz
	Setting Range	0.00Hz ~maximum frequency P0-10	

This parameter is valid only when the frequency source is set to "X and Y operation".

The final frequency is obtained by adding the frequency offset set in this parameter to the X and Y operation result.

P0-22	Frequency reference resolution	Default	2
	Setting Range	1	0.1Hz
		2	0.01Hz

It is used to set the resolution of all frequency-related parameters.

If the resolution is 0.1 Hz, the HV580 can output up to 3200 Hz. If the resolution is 0.01 Hz, the HV580 can output up to 600.00 Hz.

Note:

Modifying this parameter will make the decimal places of all frequency-related parameters change and corresponding frequency values change.

## HV580 Series Frequency Inverter

P0-23	Retentive of digital setting frequency upon power failure		Default	0
	Setting Range	0	Not retentive	
		1	Retentive	

This parameter is valid only when the frequency source is digital setting.

If P0-23 is set to 0, the digital setting frequency value resumes to the value of P0-08 (Preset frequency) after the AC drive stops. The modification by using keys ▲ and ▼ or the terminal UP/DOWN function is cleared.

If P0-23 is set to 1, the digital setting frequency value is the set frequency at the moment when the AC drives stops. The modification by using keys ▲ and ▼ or the terminal UP/DOWN function remains effective.

P0-24	Motor parameter group selection		Default	0
	Setting Range	0	Motor parameter group 1	
		1	Motor parameter group 2	
		2	Motor parameter group 3	
		3	Motor parameter group 4	

The HV580 can drive four motors at different time. You can set the motor nameplate parameters respectively, independent motor auto-tuning, different control modes, and parameters related to running performance respectively for the four motors.

Motor parameter group 1 corresponds to groups P1 and P2. Motor parameter groups 2, 3 and 4 correspond to groups A2, A3 and A4 respectively.

You can select the current motor parameter group by using P0-24 or perform switchover between the motor parameter groups by means of a DI terminal. If motor parameters selected by means of P0-24 conflict with those selected by means of DI terminal, the selection by DI is preferred.

P0-25	Acceleration/Deceleration time base frequency		Default	0
	Setting Range	0	Maximum (P0-10)	
		1	Set frequency	
		2	100Hz	

The acceleration/deceleration time indicates the time for the AC drive to increase from 0 Hz to the frequency set in P0-25. Figure 6-1 shows the acceleration/deceleration time.

If this parameter is set to 1, the acceleration/deceleration time is related to the set frequency. If the set frequency changes frequently, the motor's acceleration/deceleration also changes.

### HV580 Series Frequency Inverter

P0-26	Base frequency for UP/DOWN modification during running		Default	0
	Setting Range	0	Running frequency	
		1	Set frequency	

This parameter is valid only when the frequency source is digital setting.

It is used to set the base frequency to be modified by using keys ▲ and ▼ or the terminal UP/DOWN function. If the running frequency and set frequency are different, there will be a large difference between the AC drive's performance during the acceleration/deceleration process.

P0-27	Binding command source to frequency source		Default	000
	Setting Range	Unit's digit	Binding operation panel command to frequency source	
		0	No binding	
		1	Frequency source by digital setting	
		2	VS	
		3	AS	
		4	VS2	
		5	PULSE setting (X5)	
		6	Multi-reference	
		7	Simple PLC	
		8	PID	
	9	Communication setting		
	Ten's digit	Binding terminal command to frequency source (0–9, same as unit's digit)		
	Hundred's digit	Binding communication command to frequency source (0–9, same as unit's digit)		

It is used to bind the three running command sources with the nine frequency sources, facilitating to implement synchronous switchover.

For details on the frequency sources, see the description of P0-03 (Main frequency source X selection).

Different running command sources can be bound to the same frequency source.

If a command source has a bound frequency source, the frequency source set in P0-03 to P0-07 no longer takes effect when the command source is effective.

### HV580 Series Frequency Inverter

P0-28	Serial communication protocol		Default	0
	Setting Range	0	MODBUS protocol	
		1	Profibus-DP bridge	
		2	CANopen bridge	

The HV580 supports Modbus, PROFIBUS-DP bridge and CANopen bridge. Select a proper protocol based on the actual requirements.

### Group P1: Motor 1 Parameters

P1-00	Motor type selection		Default	0
	Setting Range	0	Common asynchronous motor	
		1	Variable frequency asynchronous motor	
		2	Permanent magnetic synchronous motor	
P1-01	Rated motor power		Default	Model dependent
	Setting Range		0.1kW ~ 1000.0kW	
P1-02	Rated motor voltage		Default	Model dependent
	Setting Range		1V ~ 2000V	
P1-03	Rated motor current		Default	Model dependent
	Setting Range		0.01A ~ 655.35A( AC drive power <=55kW) 0.1A ~ 6553.5A( AC drive power >55kW)	
P1-04	Rated motor frequency		Default	Model dependent
	Setting Range		0.01Hz ~ maximum frequency	
P1-05	Rated motor rotational speed		Default	Model dependent
	Setting Range		1rpm ~ 65535rpm	

Set the parameters according to the motor nameplate, no matter whether V/F control or vector control is adopted.

To achieve better V/F or vector control performance, motor auto-tuning is required. The motor auto-tuning accuracy depends on the correct setting of motor nameplate parameters.

P1-06	Stator resistance (asynchronous motor)		Default	Model dependent
	Setting Range		0.001Ω ~ 65.535Ω(AC drive power ≤ 55kW) 0.0001Ω ~ 6.5535Ω(AC drive power >55kW)	

### HV580 Series Frequency Inverter

P1-07	Rotor resistance (asynchronous motor)	Default	Model dependent
	Setting Range	0.001Ω ~ 65.535Ω(AC drive power ≤ 55kW) 0.0001Ω ~ 6.5535Ω(AC drive power >55kW)	
P1-08	Leakage inductive reactance (asynchronous motor)	Default	Model dependent
	Setting Range	0.01mH ~ 655.35mH(AC drive power ≤ 55kW) 0.001mH ~ 65.535mH(AC drive power >55kW)	
P1-09	Mutual inductive reactance	Default	Model dependent
	Setting Range	0.1mH ~ 6553.5mH(AC drive power ≤ 55kW) 0.01mH ~ 655.35mH(AC drive power >55kW)	
P1-10	No-load current (asynchronous motor)	Default	Model dependent
	Setting Range	0.01A ~ P1-03(AC drive power ≤ 55kW) 0.1A ~ P1-03(AC drive power >55kW)	

The parameters in P1-06 to P1-10 are asynchronous motor parameters. These parameters are unavailable on the motor nameplate and are obtained by means of motor auto-tuning. Only P1-06 to P1-08 can be obtained through static motor auto-tuning. Through complete motor auto-tuning, encoder phase sequence and current loop PI can be obtained besides the parameters in P1-06 to P1-10.

Each time "Rated motor power" (P1-01) or "Rated motor voltage" (P1-02) is changed; the AC drive automatically restores values of P1-06 to P1-10 to the parameter setting for the common standard Y series asynchronous motor.

If it is impossible to perform motor auto-tuning onsite, manually input the values of these parameters according to data provided by the motor manufacturer.

P1-16	Stator resistance (synchronous motor)	Default	Model dependent
	Setting Range	0.001Ω ~ 65.535Ω(AC drive power ≤ 55kW) 0.0001Ω ~ 6.5535Ω(AC drive power >55kW)	

### HV580 Series Frequency Inverter

P1-17	Shaft D inductance (synchronous motor)	Default	Model dependent
	Setting Range	0.01mH ~ 655.35mH(AC drive power ≤ 55kW) 0.001mH ~ 65.535mH(AC drive power >55kW)	
P1-18	Shaft Q inductance (synchronous motor)	Default	Model dependent
	Setting Range	0.01mH ~ 655.35mH(AC drive power ≤ 55kW) 0.001mH ~ 65.535mH(AC drive power >55kW)	
P1-20	Back EMF (synchronous motor)	Default	Model dependent
	Setting Range	0.1V ~ 6553.5V	

P1-16 to P-20 is synchronous motor parameters. These parameters are unavailable on the nameplate of most synchronous motors and can be obtained by means of "Synchronous motor no-load auto-tuning". Through "Synchronous motor with-load auto-tuning", only the encoder phase sequence and installation angle can be obtained.

Each time "Rated motor power" (P1-01) or "Rated motor voltage" (P1-02) is changed; the AC drive automatically modifies the values of P1-16 to P1-20.

You can also directly set the parameters based on the data provided by the synchronous motor manufacturer.

P1-27	Encoder pulses per revolution	Default	1024
	Setting Range	1 ~ 65535	

This parameter is used to set the pulses per revolution (PPR) of ABZ or UVW incremental encoder. In CLVC mode, the motor cannot run properly if this parameter is set incorrectly.

P1-28	Encoder type	Default	0
	Setting Range	0	ABZ incremental encoder
		1	UVW incremental encoder
		2	Resolver
		3	SIN/COS encoder
		4	Wire-saving UVW encoder

The HV580 supports multiple types of encoder. Different PG cards are required for different types of encoder.

Select the appropriate PG card for the encoder used. Any of the five encoder types is applicable to synchronous motor. Only ABZ incremental encoder and resolver are applicable to asynchronous motor.

After installation of the PG card is complete, set this parameter properly based on the actual condition.

Otherwise, the AC drive cannot run properly

## HV580 Series Frequency Inverter

P1-30	A/B phase sequence of ABZ incremental encoder		Default	0
	Setting Range	0	Forward	
		1	Reserve	

This parameter is valid only for ABZ incremental encoder (P1-28 = 0) and is used to set the A/B phase sequence of the ABZ incremental encoder

It is valid for both asynchronous motor and synchronous motor. The A/B phase sequence can be obtained through "Asynchronous motor complete auto-tuning" or "Synchronous motor no-load auto-tuning".

P1-31	Encoder installation angle		Default	0.0°
	Setting Range		0.0° ~ 359.9°	

This parameter is applicable only to synchronous motor. It is valid for ABZ incremental encoder, UVW incremental encoder, resolver and wire-saving UVW encoder, but invalid for SIN/COS encoder.

It can be obtained through synchronous motor no-load auto-tuning or with-load auto-tuning. After installation of the synchronous motor is complete, the value of this parameter must be obtained by motor auto-tuning.

Otherwise, the motor cannot run properly.

P1-32	U, V, W phase sequence of UVW		Default	0
	Setting Range	0	Forward	
		1	Reverse	
P1-33	UVW encoder angle offset		Default	0.0°
	Setting Range		0.0° ~ 359.9°	

These two parameters are valid only when the UVW encoder is applied to a synchronous motor.

They can be obtained by synchronous motor no-load auto-tuning or with-load auto tuning. After installation of the synchronous motor is complete, the values of these two parameters must be obtained by motor auto-tuning. Otherwise, the motor cannot run properly.

P1-34	Number of pole pairs of resolver		Default	1
	Setting Range		1 ~ 65535	

If a resolver is applied, set the number of pole pairs properly.

## HV580 Series Frequency Inverter

P1-36	Encoder wire-break fault detection time	Default	0.0s
	Setting Range	0.0s: No action 0.1s ~ 10.0s	

This parameter is used to set the time that a wire-break fault lasts. If it is set to 0.0s, the AC drive does not detect the encoder wire-break fault.

If the duration of the encoder wire-break fault detected by the AC drive exceeds the time set in this parameter, the AC drive reports Err20.

P1-37	Auto-tuning selection	Default	0	
	Setting	0	No auto-tuning	
		1	Asynchronous motor static auto-tuning	
		2	Asynchronous motor complete auto-tuning	
		3	Static complete parameter identification	
		11	Synchronous motor with-load auto-tuning	
		12	Synchronous motor no-load auto-tuning	

0: No auto-tuning, auto-tuning is prohibited.

1: Asynchronous motor static auto-tuning

It is applicable to scenarios where complete auto-tuning cannot be performed because the asynchronous motor cannot be disconnected from the load.

Before performing static auto-tuning, properly set the motor type and motor nameplate parameters of P1-00 to P1-05 first. The AC drive will obtain parameters of P1-06 to P1-08 by static auto-tuning.

Action specification: Set this parameter to 1, and press the RUN key. Then, the AC drive starts static auto-tuning.

2: Asynchronous motor complete auto-tuning

To perform this type of auto-tuning, ensure that the motor is disconnected from the load. During the process of complete auto-tuning, the AC drive performs static auto-tuning first and then accelerates to 80% of the rated motor frequency within the acceleration time set in P0-17. The AC drive keeps running for a certain period and then decelerates to stop within deceleration time set in P0-18.

Before performing complete auto-tuning, properly set the motor type, motor nameplate parameters of P1-00 to P1-05, "Encoder type" (P1-28) and "Encoder pulses per revolution" (P1-27) first.

The AC drive will obtain motor parameters of P1-06 to P1-10, "A/B phase sequence of ABZ incremental encoder" (P1-30) and vector control current loop PI parameters of P2-13 to P2-16 by complete auto-tuning.

Action specification: Set this parameter to 2, and press the RUN key. Then, the AC drive starts complete auto tuning.



### 3: Static complete parameter identification

Suitable for no encoder, motor under stationary state to complete motor parameter self learning (the motor may be still slight shaking, need to pay attention to safety).

Before complete asynchronous machine static tuning, the motor type and motor nameplate parameter P1-00 ~ P1-05 must be set properly. After complete asynchronous machine static tuning, frequency inverter can get P1-06 ~ P1-10 five parameters

### 11: Synchronous motor with-load auto-tuning

It is applicable to scenarios where the synchronous motor cannot be disconnected from the load. During with-load auto-tuning, the motor rotates at the speed of 10 PRM.

Before performing with-load auto-tuning, properly set the motor type and motor nameplate parameters of P1-00 to P1-05 first.

By with-load auto-tuning, the AC drive obtains the initial position angle of the synchronous motor, which is a necessary prerequisite of the motor's normal running.

Before the first use of the synchronous motor after installation, motor auto-tuning must be performed.

Action specification: Set this parameter to 11, and press the RUN key. Then, the AC drive starts with-load auto-tuning.

### 12: Synchronous motor no-load auto-tuning

If the synchronous motor can be disconnected from the load, no-load auto-tuning is recommended, which will achieve better running performance compared with with-load auto-tuning.

During the process of no-load auto-tuning, the AC drive performs with-load auto-tuning first and then accelerates to 80% of the rated motor frequency within the acceleration time set in P0-17. The AC drive keeps running for a certain period and then decelerates to stop within the deceleration time set in P0-18

Before performing no-load auto-tuning, properly set the motor type, motor nameplate parameters of P1-00 to P1-05, "Encoder type" (P1-28) and "Encoder pulses per revolution" (P1-27) and "Number of pole pairs of resolver" (P1-34) first.

The AC drive will obtain motor parameters of P1-16 to P1-20, encoder related parameters of P1-30 to P1-33 and vector control current loop PI parameters of P2-13 to P2-16 by no-load auto-tuning.

Action specification: Set this parameter to 12, and press the RUN key. Then, the AC drive starts no-load auto-tuning.

Note: Motor auto-tuning can be performed only in operation panel mode.

## Group P2: Vector Control Parameters

Group P2 is valid for vector control, and invalid for V/F control.

P2-00	Speed loop proportional gain 1	Default	30
	Setting Range	1 ~ 100	
P2-01	Speed loop integral time 1	Default	0.50s
	Setting Range	0.01s ~ 10.00s	
P2-02	Switchover frequency 1	Default	5.00Hz
	Setting Range	0.00 ~ P2-05	
P2-03	Speed loop proportional gain 2	Default	20
	Setting Range	0 ~ 100	
P2-04	Speed loop integral time 2	Default	1.00s
	Setting Range	0.01s ~ 10.00s	
P2-05	Switchover frequency 2	Default	10.00Hz
	Setting Range	P2-02 ~ maximum output frequency	

Speed loop PI parameters vary with running frequencies of the AC drive.

- If the running frequency is less than or equal to "Switchover frequency 1" (P2-02), the speed loop PI parameters are P2-00 and P2-01.
- If the running frequency is equal to or greater than "Switchover frequency 2" (P2-05), the speed loop PI parameters are P2-03 and P2-04.
- If the running frequency is between P2-02 and P2-05, the speed loop PI parameters are obtained from the linear switchover between the two groups of PI parameters, as shown in Figure 6-2.

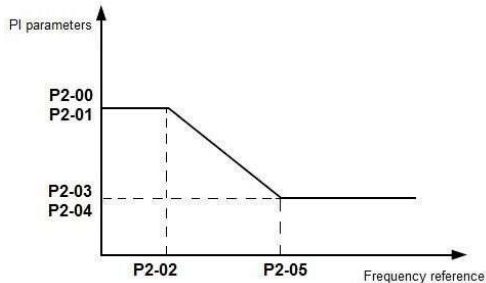

Figure 6-2: Relationship between running frequencies and PI parameters

The speed dynamic response characteristics in vector control can be adjusted by setting the proportional gain and integral time of the speed regulator.

To achieve a faster system response, increase the proportional gain and reduce the integral time. Be aware that this may lead to system oscillation.

## HV580 Series Frequency Inverter

---

The recommended adjustment method is as follows:

If the factory setting cannot meet the requirements, make proper adjustment. Increase the proportional gain first to ensure that the system does not oscillate, and then reduce the integral time to ensure that the system has quick response and small overshoot.

Note: Improper PI parameter setting may cause too large speed overshoot, and over voltage fault may even occur when the overshoot drops.

P2-06	Vector control slip gain	Default	100%
	Setting Range	50% ~ 200%	

For SFVC, it is used to adjust speed stability accuracy of the motor. When the motor with load runs at a very low speed, increase the value of this parameter; when the motor with load runs at a very large speed, decrease the value of this parameter.

For CLVC, it is used to adjust the output current of the AC drive with same load.

P2-07	Time constant of speed loop filter	Default	0.000s
	Setting Range	0.000s ~ 0.100s	

In the vector control mode, the output of the speed loop regulator is torque current reference. This parameter is used to filter the torque references. It need not be adjusted generally and can be increased in the case of large speed fluctuation. In the case of motor oscillation, decrease the value of this parameter properly.

If the value of this parameter is small, the output torque of the AC drive may fluctuate greatly, but the response is quick.

P2-08	Vector control over-excitation gain	Default	64
	Setting Range	0 ~ 200	

During deceleration of the AC drive, over-excitation control can restrain rise of the bus voltage to avoid the over voltage fault. The larger the over-excitation gain is, the better the restraining effect is.

Increase the over-excitation gain if the AC drive is liable to over voltage error during deceleration. Too large over-excitation gain, however, may lead to an increase in output current. Therefore, set this parameter to a proper value in actual applications.

Set the over-excitation gain to 0 in applications of small inertia (the bus voltage will not rise during deceleration) or where there is a braking resistor.

## HV580 Series Frequency Inverter

P2-09	Torque upper limit source in speed control mode		Default	0
	Setting Range	0	P2-10	
		1	VS	
		2	AS	
		3	VS2	
		4	PULSE setting (X5)	
5	Communication setting			
P2-10	Digital setting of torque upper limit in speed control mode		Default	150.0%
	Setting Range		0.0% ~ 200.0%	

In the speed control mode, the maximum output torque of the AC drive is restricted by P2-09.

If the torque upper limit is analog, pulse or communication setting, 100% of the setting corresponds to the value of P2-10, and 100% of the value of P2-10 corresponds to the AC drive rated torque.

P2-13	Excitation adjustment proportional gain		Default	2000
	Setting Range		0 ~ 20000	
P2-14	Excitation adjustment integral gain		Default	1300
	Setting Range		0 ~ 20000	
P2-15	Torque adjustment proportional gain		Default	2000
	Setting Range		0 ~ 20000	
P2-16	Torque adjustment integral gain		Default	1300
	Setting Range		0 ~ 20000	

These are current loop PI parameters for vector control. These parameters are automatically obtained through "Asynchronous motor complete auto-tuning" or "Synchronous motor no-load auto-tuning", and do not need to be modified.

The dimension of the current loop integral regulator is integral gain rather than integral time.

Note that too large current loop PI gain may lead to oscillation of the entire control loop.

Therefore, when current oscillation or torque fluctuation is great, manually decrease the proportional gain or integral gain here.

## HV580 Series Frequency Inverter

P2-18	Field weakening mode of synchronous motor	Default	0
	Setting Range	0	No field weakening
		1	Direct calculation
		2	Automatic adjustment
P2-19	Field weakening depth of synchronous motor	Default	100%
	Setting Range	50% ~ 500%	
P2-20	Maximum field weakening current	Default	50%
	Setting Range	1% ~ 300%	
P2-21	Field weakening automatic adjustment gain	Default	100%
	Setting Range	10% ~ 500%	
P2-22	Field weakening integral multiple	Default	2
	Setting Range	2 ~ 10	

These parameters are used to set field weakening control for the synchronous motor.

If P2-18 is set to 0, field weakening control on the synchronous motor is disabled. In this case, the maximum rotational speed is related to the AC drive bus voltage. If the motor's maximum rotational speed cannot meet the requirements, enable the field weakening function to increase the speed.

The HV580 provides two field weakening modes: direct calculation and automatic adjustment.

- In direct calculation mode, directly calculate the demagnetized current and manually adjust the demagnetized current by means of P2-19. The smaller the demagnetized current is, the smaller the total output current is. However, the desired field weakening effect may not be achieved.
- In automatic adjustment mode, the best demagnetized current is selected automatically. This may influence the system dynamic performance or cause instability.

The adjustment speed of the field weakening current can be changed by modifying the values of P2-21 and P2-22. A very quick adjustment may cause instability. Therefore, generally do not modify them manually.

### Group P3: V/F Control Parameters

Group P3 is only valid for VF control.

## HV580 Series Frequency Inverter

The VF control mode is applicable to low load applications (fan or pump) or applications where one AC drive operates multiple motors or there is a large difference between the AC drive power and the motor power.

P3-00	V/F curve setting	Default	0	
	Setting Range	0	Linear VF	
		1	Multi-point VF	
		2	Square VF	
		3	1.2-power VF	
		4	1.4-power VF	
		6	1.6-power VF	
		8	1.8-power VF	
		9	Reserved	
		10	VF complete separation	
		11	VF half separation	

0: Linear V/F. It is applicable to common constant torque load.

1: Multi-point VF. It is applicable to special load such as dehydrator and centrifuge. Any such VF curve can be obtained by setting parameters of P3-03 to P3-08.

2: Square VF. It is applicable to centrifugal loads such as fan and pump.

3~8: VF curve between linear VF and square VF

10: VF complete separation. In this mode, the output frequency and output voltage of the AC drive are independent. The output frequency is determined by the frequency source, and the output voltage is determined by "Voltage source for VF separation" (P3-13).

It is applicable to induction heating, inverse power supply and torque motor control.

11: VF half separation

In this mode, V and F are proportional and the proportional relationship can be set in P3-13. The relationship between V and F are also related to the rated motor voltage and rated motor frequency in Group P1.

Assume that the voltage source input is X (0 to 100%), the relationship between V and F is:

$$VF = 2 \times X \times (\text{Rated motor voltage}) / (\text{Rated motor frequency})$$

P3-01	Torque boost	Default	Model dependent
	Setting Range	0.0% ~ 30%	
P3-02	Cut-off frequency of torque boost	Default	50.00Hz
	Setting Range	0.00Hz ~ maximum output frequency	

To compensate the low frequency torque characteristics of V/F control, you can boost the output voltage of the

## HV580 Series Frequency Inverter

AC drive at low frequency by modifying P3-01. If the torque boost is set to too large, the motor may overheat, and the AC drive may suffer over current.

If the load is large and the motor startup torque is insufficient, increase the value of P3-01.

If the load is small, decrease the value of P3-01. If it is set to 0.0, the AC drive performs automatic torque boost. In this case, the AC drive automatically calculates the torque boost value based on motor parameters including the stator resistance.

P3-02 specifies the frequency under which torque boost is valid. Torque boost becomes invalid when this frequency is exceeded, as shown in the following figure 6-3.

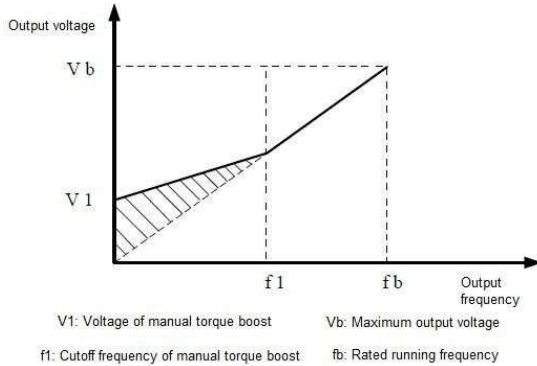

Figure 6-3 Manual torque boost

P3-03	Multi-point VF frequency	Default	0.00Hz
	P1	Setting Range 0.00Hz ~ P3-05	
P3-04	Multi-point VF voltage V1	Default	0.0%
	Setting Range	0.0% ~ 100.0%	
P3-05	Multi-point VF frequency	Default	0.00Hz
	P2	Setting Range P3-03 ~ P3-07	
P3-06	Multi-point VF voltage V2	Default	0.0%
	Setting Range	0.0% ~ 100.0%	

## HV580 Series Frequency Inverter

P3-07	Multi-point VF frequency P3	Default	0.00Hz
	Setting Range	P3-05 ~ rated motor frequency (P1-04) Note: The rated frequencies of motors 2, 3, and 4 are	
P3-08	Multi-point VF voltage V3	Default	0.0%
	Setting Range	0.0% ~ 100.0%	

These six parameters are used to define the multi-point VF curve.

The multi-point VF curve is set based on the motor's load characteristic. The relationship between voltages and frequencies is:

$$V1 < V2 < V3, P1 < P2 < P3$$

At low frequency, higher voltage may cause overheat or even burnt out of the motor and over current stall or over current protection of the AC drive.

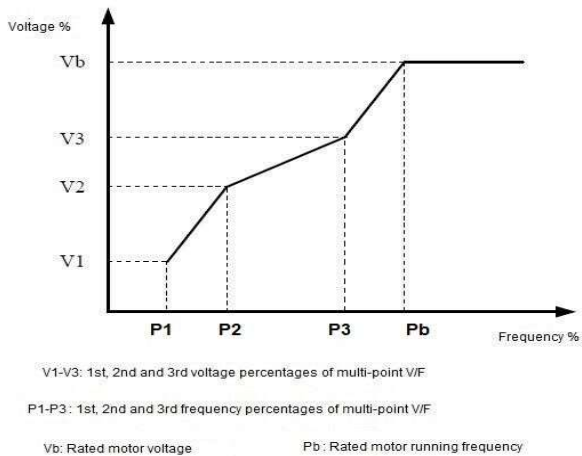

Figure 6-4 Setting of multi-point VF curve

P3-09	VF slip compensation gain	Default	0.0%
	Setting Range	0% ~ 200.0%	

This parameter is valid only for the asynchronous motor.

It can compensate the rotational speed slip of the asynchronous motor when the load of the motor increases, stabilizing the motor speed in case of load change.

If this parameter is set to 100%, it indicates that the compensation when the motor bears rated load is the rated motor slip. The rated motor slip is automatically obtained by the AC drive through calculation based on



## HV580 Series Frequency Inverter

the rated motor frequency and rated motor rotational speed in group P1.

Generally, if the motor rotational speed is different from the target speed, slightly adjust this parameter.

P3-10	VF over-excitation gain	Default	64
	Setting	0 ~ 200	

During deceleration of the AC drive, over-excitation can restrain rise of the bus voltage, preventing the over voltage fault. The larger the over-excitation is, the better the restraining result is.

Increase the over-excitation gain if the AC drive is liable to over voltage error during deceleration. However, too large over-excitation gain may lead to an increase in the output current. Set P3-09 to a proper value in actual applications.

Set the over-excitation gain to 0 in the applications where the inertia is small and the bus voltage will not rise during motor deceleration or where there is a braking resistor.

P3-11	VF oscillation suppression gain	Default	Model dependent
	Setting Range	0 ~ 100	

Set this parameter to a value as small as possible in the prerequisite of efficient oscillation suppression to avoid influence on VF control.

Set this parameter to 0 if the motor has no oscillation. Increase the value properly only when the motor has obvious oscillation. The larger the value is, the better the oscillation suppression result will be.

When the oscillation suppression function is enabled, the rated motor current and no-load current must be correct. Otherwise, the VF oscillation suppression effect will not be satisfactory.

P3-13	VF Voltage source for VF separation	Default	0
	Setting Range	0	Digital setting (P3-14)
		1	VS
		2	AS
		3	VS2
		4	PULSE setting (X5)
		5	Multi-reference
		6	Simple PLC
		7	PID
		8	Communication setting
100.0% corresponds to the rated motor voltage (P1-02, A2-02, A3-02, A4-02)			

VF separation is generally applicable to scenarios such as induction heating, inverse power supply and motor torque control.

## HV580 Series Frequency Inverter

---

If VF separated control is enabled, the output voltage can be set in P3-14 or by means of analog, multi-reference, simple PLC, PID or communication. If you set the output voltage by means of non-digital setting, 100% of the setting corresponds to the rated motor voltage. If a negative percentage is set, its absolute value is used as the effective value.

### 0: Digital setting (P3-14)

The output voltage is set directly in P3-14.

1: VS    2: AS    3: VS2

The output voltage is set by VS terminals.

### 4: PULSE setting (X5)

The output voltage is set by pulses of the terminal X5.

Pulse setting specification: voltage range 9–30 V, frequency range 0–100 kHz

### 5: Multi-reference

If the voltage source is multi-reference, parameters in group P4 and PC must be set to determine the corresponding relationship between setting signal and setting voltage.

### 6: Simple PLC

If the voltage source is simple PLC mode, parameters in group PC must be set to determine the setting output voltage.

### 7: PID

The output voltage is generated based on PID closed loop. For details, see the description of PID in group PA.

### 8: Communication setting

The output voltage is set by the host computer by means of communication.

When the voltage source to choose 1 ~ 8, 0 ~ 100% are corresponding to the output voltage of 0 V~ motor rated voltage.

P3-14	VF Separation of digital voltage setting	Default	0V
	Setting Range	0V ~ Motor Rated Voltage	
P3-15	Voltage rise time of VF separation	Default	0.0s
	Setting Range	0.0s ~ 1000.0s	
P3-15	Voltage decline time of VF separation	Default	0.0s
	Setting Range	0.0s ~ 1000.0s	

## HV580 Series Frequency Inverter

The voltage source for VF separation is set in the same way as the frequency source. For details, see P0-03. 100.0% of the setting in each mode corresponds to the rated motor voltage. If the corresponding value is negative, its absolute value is used

P3-15 indicates the time required for the output voltage to rise from 0 V to the rated motor voltage shown as  $t_1$  in the following figure.

P3-16 indicates the time required for the output voltage to decline from the rated motor voltage to 0 V, shown as  $t_2$  in the following figure.

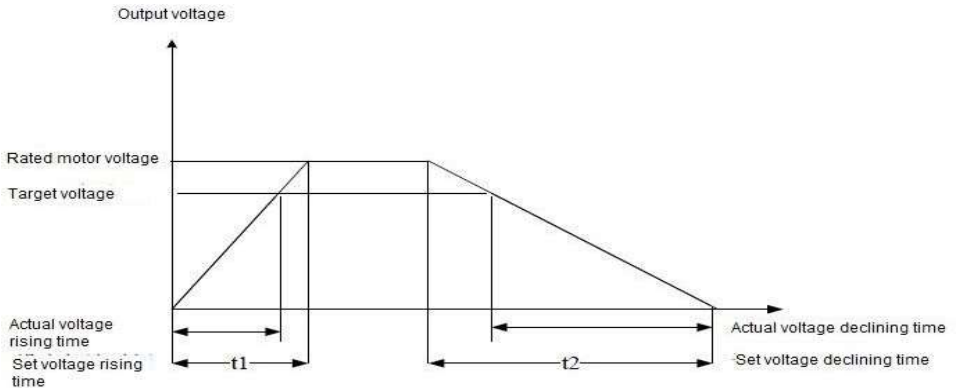

Figure 6-5 Voltage of V/F separation

### Group P4: Input Terminals

The HV580 provides five DI terminals (X5 can be used for high-speed pulse input) and two analog input (AI) terminals. The optional extension card provides another five DI terminals (DI6 to DI10) and an AI terminal (AI3).

Multi-function input/output expansion card has five multi-function digital input terminals (X6 ~ X10), one analog input (VS2).

Function Code	Parameter Name	Default	Remark
P4-00	X1 function selection	1: Forward RUN (FWD)	Standard
P4-01	X2 function selection	4: Forward JOG (FJOG)	Standard
P4-02	X3 function selection	9: Fault reset (RESET)	Standard
P4-03	X4 function selection	12: Multi-reference terminal 1	Standard
P4-04	X5 function selection	13: Multi-reference terminal 2	Standard
P4-05	X6 function selection	0	Extended

### HV580 Series Frequency Inverter

P4-06	X7 function selection	0	Extended
P4-07	X8 function selection	0	Extended
P4-08	X9 function selection	0	Extended
P4-09	X10 function selection	0	Extended

The following table lists the functions available for the X terminals.

Value	Function	Description
0	No function	Set 0 for reserved terminals to avoid malfunction.
1	Forward RUN (FWD)	The terminal is used to control forward or reverse RUN of the AC drive.
2	Reverse RUN (REV)	
3	Three-line control	The terminal determines three-line control of the AC drive. For details, see the description of P4-11.
4	Forward JOG (FJOG)	FJOG indicates forward JOG running, while RJOG indicates reverse JOG running. The JOG frequency, acceleration time and deceleration time are described respectively in P8-00, P8-01 and P8-02.
5	Reverse JOG (RJOG)	
6	Terminal UP	If the frequency is determined by external terminals, the terminals with the two functions are used as increment and decrement commands for frequency modification. When the frequency source is digital setting, they are used to adjust the frequency.
7	Terminal DOWN	
8	Coast to stop	The AC drive blocks its output, the motor coasts to rest and is not controlled by the AC drive. It is the same as coast to stop described in P6-10.
9	Fault reset (RESET)	The terminal is used for fault reset function, the same as the function of RESET key on the operation panel. Remote fault reset is implemented by this function.
10	RUN pause	The AC drive decelerates to stop, but the running parameters are all memorized, such as PLC, swing frequency and PID parameters. After this function is disabled, the AC drive resumes its status before stop.
11	Normally open (NO) input of external fault	If this terminal becomes ON, the AC drive reports Err15 and performs the fault protection action. For more details, see the description of P9-47.
Value	Function	Description

HV580 Series Frequency Inverter

12	Multi-reference terminal 1	The setting of 16 speeds or 16 other references can be implemented through combinations of 16 states of these four terminals. For more details, see appendix 1.
13	Multi-reference terminal 2	
14	Multi-reference terminal 3	
15	Multi-reference terminal 4	
16	Terminal 1 for acceleration/deceleration time selection	Totally four groups of acceleration/deceleration time can be selected through combinations of two states of these two terminals. For more details, see appendix 2.
17	Terminal 2 for acceleration/deceleration time selection	
18	Frequency source switchover	The terminal is used to perform switchover between two frequency sources according to the setting in P0-07.
19	UP/DOWN setting clear (terminal, operation panel)	If the frequency source is digital setting, the terminal is used to clear the modification by using the UP/DOWN function or the increment/decrement key on the operation panel, returning the set frequency to the value of P0-08.
20	Command source switchover terminal	If the command source is set to terminal control (P0-02 = 1), this terminal is used to perform switchover between terminal control and operation panel control. If the command source is set to communication control (P0-02 = 2), this terminal is used to perform switchover between communication control and operation panel control.
21	Acceleration/Deceleration prohibited	It enables the AC drive to maintain the current frequency output without being affected by external signals (except the STOP command).
22	PID pause	PID is invalid temporarily. The AC drive maintains the current frequency output without supporting PID adjustment of frequency source.
23	PLC pause	The terminal is used to restore the original status of PLC control for the AC drive when PLC control is started again after a pause.

HV580 Series Frequency Inverter

24	Swing pause	The AC drive outputs the central frequency, and the swing frequency function pauses.
25	Counter input	This terminal is used to count pulses.
26	Counter reset	This terminal is used to clear the counter status.
27	Length count input	This terminal is used to count the length.
28	Length reset	This terminal is used to clear the length.
29	Torque control prohibited	The AC drive is prohibited from torque control and enters the speed control mode.
30	Pulse input (enabled only for X5)	X5 is used for pulse input.
31	Reserved	Reserved
32	Immediate DC braking	After this terminal becomes ON, the AC drive directly switches over to the DC braking state.
33	Normally closed (NC) input of external fault	After this terminal becomes ON, the AC drive reports Err15 and stops.
34	Frequency modification forbidden	After this terminal becomes ON, the AC drive does not respond to any frequency modification.
35	Reverse PID action direction	After this terminal becomes ON, the PID action direction is reversed to the direction set in PA-03.
36	External STOP terminal 1	In operation panel mode, this terminal can be used to stop the AC drive, equivalent to the function of the STOP key on the operation panel.
37	Command source switchover terminal 2	It is used to perform switchover between terminal control and communication control. If the command source is terminal control, the system will switch over to communication control after this terminal becomes ON.
38	PID integral pause	After this terminal becomes ON, the integral adjustment function pauses. However, the proportional and differentiation adjustment functions are still valid.
39	Switchover between main frequency source X and preset frequency	After this terminal becomes ON, the frequency source X is replaced by the preset frequency set in P0-08.

HV580 Series Frequency Inverter

Value	Function	Description
40	Switchover between auxiliary frequency source Y and preset frequency	After this terminal is enabled, the frequency source Y is replaced by the preset frequency set in P0-08.
41	Motor selection terminal 1	Switchover among the four groups of motor parameters can be implemented through the four state combinations of these two terminals. For more details, see appendix 3.
42	Motor selection terminal 2	
43	PID parameter switchover	If the PID parameters switchover performed by means of DI terminal (PA-18 = 1), the PID parameters are PA-05 to PA-07 when the terminal becomes OFF; the PID parameters are PA-15 to PA-17 when this terminal becomes ON.
44	User-defined fault 1	If these two terminals become ON, the AC drive reports Err27 and Err28 respectively, and performs fault protection actions based on the setting in P9-49.
45	User-defined fault 2	
46	Speed control / Torque control switchover	This terminal enables the AC drive to switch over between speed control and torque control. When this terminal becomes OFF, the AC drive runs in the mode set in A0-00. When this terminal becomes ON, the AC drive switches over to the other control mode.
47	Emergency stop	When this terminal becomes ON, the AC drive stops within the shortest time. During the stop process, the current remains at the set current upper limit. This function is used to satisfy the requirement of stopping the AC drive in emergency state.
48	External STOP terminal 2	In any control mode (operation panel, terminal or communication), it can be used to make the AC drive decelerate to stop. In this case, the deceleration time is deceleration time 4.
49	Deceleration DC braking	When this terminal becomes ON, the AC drive decelerates to the initial frequency of stop DC braking and then switches over to DC braking state.
50	Clear the current running time	When this terminal becomes ON, the AC drive's current running time is cleared. This function must be supported by P8-42 and P8-53.

**Appendix 1: State combinations of the four multi-reference terminals**

## HV580 Series Frequency Inverter

The four multi-reference terminals have 16 state combinations, corresponding to 16 reference values, as listed in the following table:

K4	K3	K2	K1	Reference Setting	Corresponding Parameter
OFF	OFF	OFF	OFF	Reference 0	PC-00
OFF	OFF	OFF	ON	Reference 1	PC-01
OFF	OFF	ON	OFF	Reference 2	PC-02
OFF	OFF	ON	ON	Reference 3	PC-03
OFF	ON	OFF	OFF	Reference 4	PC-04
OFF	ON	OFF	ON	Reference 5	PC-05
OFF	ON	ON	OFF	Reference 6	PC-06
OFF	ON	ON	ON	Reference 7	PC-07
ON	OFF	OFF	OFF	Reference 8	PC-08
ON	OFF	OFF	ON	Reference 9	PC-09
ON	OFF	ON	OFF	Reference 10	PC-10
ON	OFF	ON	ON	Reference 11	PC-11
ON	ON	OFF	OFF	Reference 12	PC-12
ON	ON	OFF	ON	Reference 13	PC-13
ON	ON	ON	OFF	Reference 14	PC-14
ON	ON	ON	ON	Reference 15	PC-15

If the frequency source is multi-reference, the value 100% of PC-00 to PC-15 corresponds to the value of P0-10 (Maximum frequency).

Besides the multi-speed function, the multi-reference can be also used as the PID setting source or the voltage source for VF separation, satisfying the requirement on switchover of different setting values.

### Appendix 2: State combinations of two terminals for acceleration/deceleration time selection

Terminal 2	Terminal 1	Acceleration/Deceleration Time Selection	Corresponding Parameters
OFF	OFF	Acceleration/Deceleration time 1	P0-17、P0-18
OFF	ON	Acceleration/Deceleration time 2	P8-03、P8-04
ON	OFF	Acceleration/Deceleration time 3	P8-05、P8-06
ON	ON	Acceleration/Deceleration time 4	P8-07、P8-08



**Appendix 3: State combinations of two motor selection terminals**

Terminal 2	Terminal 1	Selected Motor	Corresponding Parameters
OFF	OFF	Motor 1	Group P1, P2
OFF	ON	Motor 2	Group A2
ON	OFF	Motor 3	Group A3
ON	ON	Motor 4	Group A4

P4-10	X filter time	Default	0.010s
	Setting Range	0.000s ~ 1.000s	

It is used to set the software filter time of X terminal status. If X terminals are liable to interference and may cause malfunction, increase the value of this parameter to enhance the anti-interference capability. However, increase of X filter time will reduce the response of X terminals.

P4-11	Terminal command mode	Default	0
	Setting Range	0	Two-line mode 1
		1	Two-line mode 2
		2	Three-line mode 1
		3	Three-line mode 2

This parameter is used to set the mode in which the AC drive is controlled by external terminals.

0: Two-line mode 1: It is the most commonly used two-line mode, in which the forward/reverse rotation of the motor is decided by X1 and X2. The parameters are set as below:

Function Code	Parameter Name	Value	Function Description
P4-11	Terminal command mode	0	Two-line 1
P4-00	X1 function selection	1	Forward RUN (FWD)
P4-01	X2 function selection	2	Reverse RUN (REV)

K1	K2	RUN command
1	0	Forward RUN
0	1	Reverse RUN
1	1	Stop
0	0	Stop

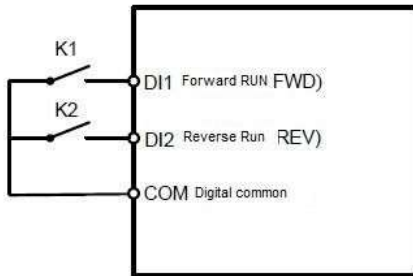

Figure 6-6 Setting of two-line mode 1

1: Two-line mode 2

In this mode, X1 is RUN enabled terminal, and DI2 determines the running direction.

The parameters are set as below:

Function Code	Parameter Name	Value	Function Description
P4-11	Terminal command mode	1	Two-line 2
P4-00	X1 function selection	1	RUN enabled
P4-01	DI2 function selection	2	Forward or reverse

K1	K2	RUN command
1	0	Forward RUN
1	1	Reverse RUN
0	0	Stop
0	1	Stop

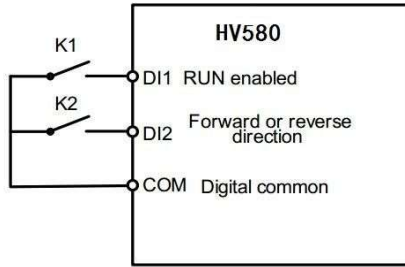

Figure 6-7 Setting of two-line mode 2

As shown in the preceding figure, if K1 is ON, the AC drive instructs forward rotation when K2 is OFF, and instructs reverse rotation when K2 is ON. If K1 is OFF, the AC drive stops.

2: Three-line mode 1

In this mode, DI3 is RUN enabled terminal, and the direction is decided by X1 and DI2.

The parameters are set as below:

Function Code	Parameter Name	Value	Function Description
P4-11	Terminal command mode	2	Three-line 1
P4-00	X1 function selection	1	Forward RUN (FWD)
P4-01	X2 function selection	2	Reverse RUN (REV)
P4-02	X3 function selection	3	Three-line control

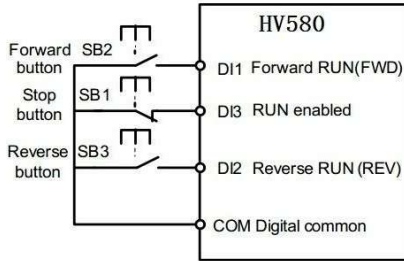

Figure 6-8 Setting of three-line mode 1

As shown in the preceding figure, if SB1 is ON, the AC drive instructs forward rotation when SB2 is pressed to be ON and instructs reverse rotation when SB3 is pressed to be ON. The AC drive stops immediately after SB1 becomes OFF. During normal startup and running, SB1 must remain ON. The AC drive's running state is determined by the final actions on SB1, SB2 and SB3.

3: Three-line mode 2

In this mode, X3 is RUN enabled terminal. The RUN command is given by X1 and the direction is decided by X2. The parameters are set as below:

Function Codes are set as below:

Function Code	Parameter Name	Value	Function Description
P4-11	Terminal command mode	3	Three-line 2
P4-00	X1 function selection	1	RUN enabled
P4-01	X2 function selection	2	Forward or reverse
P4-02	X3 function selection	3	Three-line control

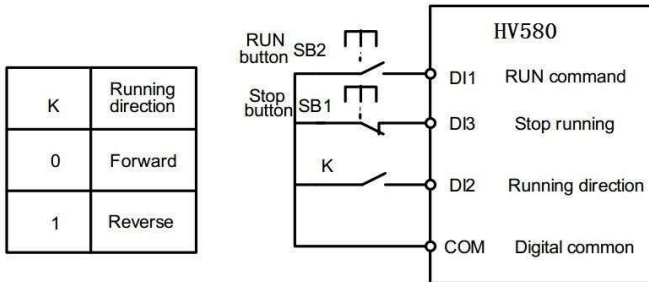

Figure 6-9 Setting of three-line mode 2

## HV580 Series Frequency Inverter

As shown in the preceding figure, if SB1 is ON, the AC drive starts running when SB2 is pressed to be ON; the AC drive instructs forward rotation when K is OFF and instructs reverse rotation when K is ON. The AC drive stops immediately after SB1 becomes OFF. During normal startup and running, SB1 must remain ON. The AC drive's running state is determined by the final actions of SB1, SB2 and K.

P4-12	Terminal UP/DOWN rate	Default	1.00Hz/s
	Setting Range	0.01Hz/s ~ 65.535Hz/s	

It is used to adjust the rate of change of frequency when the frequency is adjusted by means of terminal UP/DOWN.

If P0-22 (Frequency reference resolution) is 2, the setting range is 0.001–65.535 Hz/s.

If P0-22 (Frequency reference resolution) is 1, the setting range is 0.01–655.35 Hz/s.

P4-13	VS curve 1 minimum input	Default	0.00V
	Setting Range	0.00V ~ P4-15	
P4-14	Corresponding setting of VS curve 1 minimum input	Default	0.0%
	Setting Range	-100.00% ~ 100.0%	
P4-15	VS curve 1 maximum input	Default	10.00V
	Setting Range	P4-13 ~ 10.00V	
P4-16	Corresponding setting of VS curve 1 maximum input	Default	100.0%
	Setting Range	-100.00% ~ 100.0%	
P4-17	VS1 filter time	Default	0.10s
	Setting Range	0.00s ~ 10.00s	

## HV580 Series Frequency Inverter

These parameters are used to define the relationship between the analog input voltage and the corresponding setting.

When the analog input voltage exceeds the maximum value (P4-15), the maximum value is used. When the analog input voltage is less than the minimum value (P4-13), the value set in P4-34 (Setting for VS less than minimum input) is used.

When the analog input is current input, 1 mA current corresponds to 0.5 V voltages.

P4-17 (VS 1 filter time) is used to set the software filter time of VS. If the analog input is liable to interference, increase the value of this parameter to stabilize the detected analog input. However, increase of the AI filter time will slow the response of analog detection. Set this parameter properly based on actual conditions.

In different applications, 100% of analog input corresponds to different nominal values. For details, refer to the description of different applications.

Two typical setting examples are shown in the following figure.

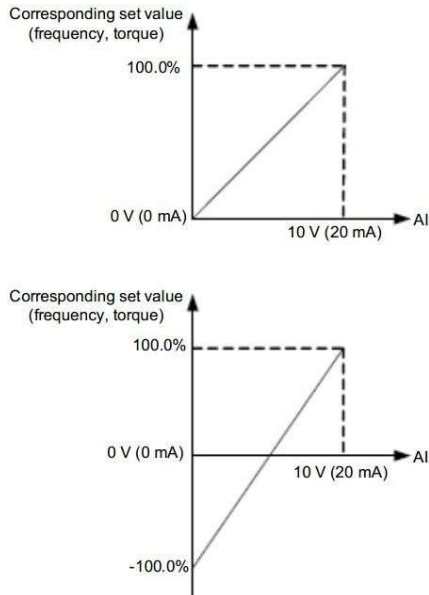

Figure 6-10 Corresponding relationship between analog input and set values

### HV580 Series Frequency Inverter

P4-18	AS curve minimum input	Default	0.00V
	Setting Range	0.00V ~ P4-20	
P4-19	Corresponding setting of AS curve minimum input	Default	0.0%
	Setting Range	-100.00% ~ 100.0%	
P4-20	AS curve maximum input	Default	10.00V
	Setting Range	P4-18 ~ 10.00V	
P4-21	Corresponding setting of AS curve maximum input	Default	100.0%
	Setting Range	-100.00% ~ 100.0%	
P4-22	AS filter time	Default	0.10s
	Setting Range	0.00s ~ 10.00s	

The method of setting AS functions is similar to that of setting VS1 function.

P4-23	VS curve 2 minimum input	Default	0.00V
	Setting Range	0.00s ~ P4-25	
P4-24	Corresponding setting of VS curve 2 minimum input	Default	0.0%
	Setting Range	-100.00% ~ 100.0%	
P4-25	VS curve 2 maximum input	Default	10.00V
	Setting Range	P4-23 ~ 10.00V	
P4-26	Corresponding setting of VS curve 2 maximum input	Default	100.0%
	Setting Range	-100.00% ~ 100.0%	
P4-27	VS2 filter time	Default	0.10s
	Setting Range	0.00s ~ 10.00s	

The method of setting VS 2 functions is similar to that of setting VS1 function.

### HV580 Series Frequency Inverter

P4-28	PULSE minimum input	Default	0.00kHz
	Setting Range	0.00kHz ~ P4-30	
P4-29	Corresponding setting of pulse minimum input	Default	0.0%
	Setting Range	-100.00% ~ 100.0%	
P4-30	Pulse maximum input	Default	50.00kHz
	Setting Range	P4-28 ~ 50.00kHz	
P4-31	Corresponding setting of pulse maximum input	Default	100.0%
	Setting Range	-100.00% ~ 100.0%	
P4-32	PULSE filter time	Default	0.10s
	Setting Range	0.00s ~ 10.00s	

These parameters are used to set the relationship between X5 pulse input and corresponding settings. The pulses can only be input by X5. The method of setting this function is similar to that of setting VS 1function.

P4-33	VS curve selection		Default	321
	Setting Range	Unit's digit	VS curve selection	
		1	Curve 1 (2 points, see P4-13 ~ P4-16)	
		2	Curve 2 (2 points, see P4-18 ~ P4-21)	
		3	Curve 3 (2 points, see P4-23 ~ P4-26)	
		4	Curve 4 (4 points, see A6-00 ~ A6-07)	
		5	Curve 5 (4 points, see A6-08 ~ A6-15)	
		Ten's digit	AS curve selection (1 ~ 5, same to VS1)	
Hundred's digit	VS2 curve selection (1 ~ 5, same to VS1)			

The unit's digit, ten's digit and hundred's digit of this parameter are respectively used to select the corresponding curve of VS1, AS and VS2. Any of the five curves can be selected for VS1, AS and VS2. Curve 1, curve 2 and curve 3 are all 2-point curves, set in group P4. Curve 4 and curve 5 are both 4-point curves, set in group A6.

The HV580 provides two AI terminals as standard. VS2 is provided by an optional extension card.

HV580 Series Frequency Inverter

P4-34	Setting for VS less than minimum input		Default	000
	Setting Range	Unit's digit	Setting for VS1 less than minimum input	
		0	Minimum value	
		1	0.0%	
		Ten's digit	Setting for AS less than minimum input (0 ~ 1, same to VS1)	
		Hundred's digit	Setting for VS2 less than minimum input (0 ~ 1, same to VS1)	

This parameter is used to determine the corresponding setting when the analog input voltage is less than the minimum value. The unit's digit, ten's digit and hundred's digit of this parameter respectively correspond to the setting for VS2, AS and VS2.

If the value of a certain digit is 0, when analog input voltage is less than the minimum input, the corresponding setting of the minimum input (P4-14, P4-19, P4-24) is used.

If the value of a certain digit is 1, when analog input voltage is less than the minimum input, the corresponding value of this analog input is 0.0%.

P4-35	X1 delay time	Default	0.0s
	Setting Range	0.0s ~ 3600.0s	
P4-36	X2 delay time	Default	0.0s
	Setting Range	0.0s ~ 3600.0s	
P4-37	X3 delay time	Default	0.0s
	Setting Range	0.0s ~ 3600.0s	

These parameters are used to set the delay time of the AC drive when the status of X terminals changes.

Currently, only X1, X2 and X3 support the delay time function.

P4-38	X valid mode selection 1		Default	00000
	Setting Range	Unit's digit	X1 valid mode	
		0	High level valid	
		1	Low level valid	
		Ten's digit	X2 valid mode (0 ~ 1, same as X1)	
		Hundred's digit	X3 valid mode (0 ~ 1, same as X1)	
		Thousand's digit	X4 valid mode (0 ~ 1, same as X1)	
		Ten thousand's digit	X5 valid mode (0 ~ 1, same as X1)	



## HV580 Series Frequency Inverter

P4-39	X valid mode selection 2		Default	00000
	Setting Range	Unit's digit	X6 valid mode	
		0	High level valid	
		1	Low level valid	
		Ten's digit	X7 valid mode (0 ~ 1, same as X1)	
		Hundred's digit	X8 valid mode (0 ~ 1, same as X1)	
		Thousand's digit	X9 valid mode (0 ~ 1, same as X1)	
		Ten thousand's digit	X10 valid mode (0 ~ 1, same as X1)	

These parameters are used to set the valid mode of DI terminals.

0: High level valid

The X terminal is valid when being connected with COM, and invalid when being disconnected from COM.

1: Low level valid

The DI terminal is invalid when being connected with COM, and valid when being disconnected from COM.

### Group P5: Output Terminals

The HV580 provides an analog output (AO) terminal, a digital output (DO) terminal, a relay terminal and a FM terminal (used for high-speed pulse output or open-collector switch signal output) as standard. If these output terminals cannot satisfy requirements, use an optional I/O extension card that provides an AO terminal (AO2), a relay terminal (relay 2) and a DO terminal (DO2).

P5-00	Y2 terminal output mode		Default	0
	Setting Range	0	Pulse output (Y2P)	
		1	Switch signal output (Y2R)	

The Y2 terminal is programmable multiplexing terminal. It can be used for high-speed pulse output (Y2P), with maximum frequency of 100 kHz. Refer to P5-06 for relevant functions of Y2P. It can also be used as open collector switch signal output (Y2R).

P5-01	Y2R function (open-collector output terminal)	Default	0
P5-02	Relay function (T/A-T/B-T/C)	Default	2
P5-03	Extension card relay function (P/A-P/B-P/C)	Default	0
P5-04	Y1 function selection (open-collector output terminal)	Default	1
P5-05	Extension card DO2 function	Default	4

These five parameters are used to select the functions of the five digital output terminals. T/A-T/B-T/C and P/A-P/B-P/C are respectively the relays on the control board and the extension card.

## HV580 Series Frequency Inverter

The functions of the output terminals are described in the following table.

Value	Function	Description
0	No output	The terminal has no function.
1	AC drive running	When the AC drive is running and has output frequency (can be zero), the terminal becomes ON.
2	Fault output (stop)	When the AC drive stops due to a fault, the terminal becomes ON.
3	Frequency-level detection FDT1 output	Refer to the descriptions of P8-19 and P8-20.
4	Frequency reached	Refer to the descriptions of P8-21.
5	Zero-speed running (no output at stop)	If the AC drive runs with the output frequency of 0, the terminal becomes ON. If the AC drive is in the stop state, the terminal becomes OFF.
6	Motor overload pre-warning	The AC drive judges whether the motor load exceeds the overload pre-warning threshold before performing the protection action. If the pre-warning threshold is exceeded, the terminal becomes ON. For motor overload parameters, see the descriptions of P9-00 to P9-02.
7	AC drive overload pre-warning	The terminal becomes ON 10s before the AC drive overload protection action is performed.
8	Set count value reached	The terminal becomes ON when the count value reaches the value set in PB-08.

HV580 Series Frequency Inverter

Value	Function	Description
9	Designated count value reached	The terminal becomes ON when the count value reaches the value set in PB-09.
10	Length reached	The terminal becomes ON when the detected actual length exceeds the value set in PB-05
11	PLC cycle complete	When simple PLC completes one cycle, the terminal outputs a pulse signal with width of 250 ms.
12	Accumulative running time reached	If the accumulative running time of the AC drive exceeds the time set in P8-17, the terminal becomes ON.
13	Frequency limited	If the set frequency exceeds the frequency upper limit or lower limit and the output frequency of the AC drive reaches the upper limit or lower limit, the terminal becomes ON.
14	Torque limited	In speed control mode, if the output torque reaches the torque limit, the AC drive enters the stall protection state and meanwhile the terminal becomes ON.
15	Ready for RUN	If the AC drive main circuit and control circuit become stable, and the AC drive detects no fault and is ready for RUN, the terminal becomes ON.
16	VS>AS	When the input of AI1 is larger than the input of AI2, the terminal becomes ON.
17	Frequency upper limit Reached	If the running frequency reaches the upper limit, the terminal becomes ON.
18	Frequency lower limit reached (no output at stop)	If the running frequency reaches the lower limit, the terminal becomes ON. In the stop state, the terminal becomes OFF.
19	Undervoltage state output	If the AC drive is in undervoltage state, the terminal becomes ON.
20	Communication setting	Refer to the communication protocol.
21	Reserved	Reserved.
22	Reserved	Reserved.

HV580 Series Frequency Inverter

Value	Function	Description
23	Zero-speed running 2 (having output at stop)	If the output frequency of the AC drive is 0, the terminal becomes ON. In the state of stop, the signal is still ON.
24	Accumulative power-on time reached	If the AC drive accumulative power-on time (P7-13) exceeds the value set in P8-16, the terminal becomes
25	Frequency level	Refer to the descriptions of P8-28 and P8-29.
26	Frequency 1 reached	Refer to the descriptions of P8-30 and P8-31.
27	Frequency 2 reached	Refer to the descriptions of P8-32 and P8-33.
28	Current 1 reached	Refer to the descriptions of P8-38 and P8-39.
29	Current 2 reached	Refer to the descriptions of P8-40 and P8-41.
30	Timing reached	If the timing function (P8-42) is valid, the terminal becomes ON after the current running time of the AC drive reaches the set time.
31	VS input limit exceeded	If AI1 input is larger than the value of P8-46 (AI1 input voltage upper limit) or lower than the value of P8-45 (AI1 input voltage lower limit), the terminal becomes ON.
32	Load becoming 0	If the load becomes 0, the terminal becomes ON.
33	Reverse running	If the AC drive is in the reverse running state, the terminal
34	Zero current state	Refer to the descriptions of P8-28 and P8-29.
35	Module temperature reached	If the heatsink temperature of the inverter module (P7-07) reaches the set module temperature threshold (P8-47), the terminal becomes ON.
36	Software current limit exceeded	Refer to the descriptions of P8-36 and P8-37.
37	Frequency lower limit reached (having output at stop)	If the running frequency reaches the lower limit, the terminal becomes ON. In the stop state, the signal is still ON.
38	Alarm output	If a fault occurs on the AC drive and the AC drive continues to run, the terminal outputs the alarm signal.
39	Motor overheat warning	If the motor temperature reaches the temperature set in P9-58 (Motor overheat warning threshold), the terminal becomes ON. You can view the motor temperature by using U0-34.
40	Current running time reached	If the current running time of AC drive exceeds the value of P8-53, the terminal becomes ON

## HV580 Series Frequency Inverter

P5-06	Y2P function selection (Pulse output terminal)	Default	0
P5-07	AO1 function selection	Default	0
P5-08	AO2 function selection	Default	1

The output pulse frequency of the Y2P terminal ranges from 0.01 kHz to "Maximum Y2P output frequency" (P5-09). The value of P5-09 is between 0.01 kHz and 100.00 kHz.

The output range of AO1 and AO2 is 0–10 V or 0–20 mA.

The relationship between pulse and analog output ranges and corresponding functions is listed in the following table.

Value	Function	Range (Corresponding to Pulse or Analog Output Range 0.0%–100.0%)
0	Running frequency	0 to maximum output frequency
1	Set frequency	0 to maximum output frequency
2	Output current	0 to 2 times of rated motor current
3	Output torque (absolute value)	0 to 2 times of rated motor torque
4	Output power	0 to 2 times of rated power
5	Output voltage	0 to 1.2 times of rated AC drive voltage
6	Pulse input	0.01kHz ~ 100.00kHz
7	VS	0V ~ 10V
8	AS	0V ~ 10V (Or 0 ~ 20mA)
9	VS2	0V ~ 10V
10	Length	0 ~ maximum set length
11	Count value	0 ~ maximum count value
12	Communication setting	0.0% ~ 100.0%
13	Motor rotational speed	0 ~ rotational speed corresponding to maximum output frequency
14	Output current	0.0A ~ 1000.0A
15	Output voltage	0.0V ~ 1000.0V

P5-09	Maximum Y2P output frequency	Default	50.00kHz
	Setting Range	0.01kHz ~ 100.00kHz	

If the Y2 terminal is used for pulse output, this parameter is used to set the maximum frequency of pulse output.

P5-10	AO1 offset coefficient	Default	0.0%
	Setting Range	-100.0% ~ +100.0%	
P5-11	AO1 gain	Default	1.00
	Setting Range	-10.00 ~ +10.00	

### HV580 Series Frequency Inverter

P5-12	Expansion card AO2 offset coefficient	Default	0.00%
	Setting Range	-100.0% ~ +100.0%	
P5-13	Expansion card AO2 gain	Default	1.00
	Setting Range	-10.00 ~ +10.00	

These parameters are used to correct the zero drift of analog output and the output amplitude deviation. They can also be used to define the desired AO curve.

If "b" represents zero offset, "k" represents gain, "Y" represents actual output, and "X" represents standard output, the actual output is:  $Y = kX + b$ .

The zero offset coefficient 100% of AO1 and AO2 corresponds to 10 V (or 20 mA). The standard output refers to the value corresponding to the analog output of 0 to 10 V (or 0 to 20 mA) with no zero offset or gain adjustment.

For example, if the analog output is used as the running frequency, and it is expected that the output is 8 V when the frequency is 0 and 3 V at the maximum frequency, the gain shall be set to -0.50, and the zero offset shall be set to 80%.

P5-17	Y2R output delay time	Default	0.0s
	Setting Range	0.0s ~ 3600.0s	
P5-18	RELAY1 output delay time	Default	0.0s
	Setting Range	0.0s ~ 3600.0s	
P5-19	RELAY2 output delay time	Default	0.0s
	Setting Range	0.0s ~ 3600.0s	
P5-20	Y1 output delay time	Default	0.0s
	Setting Range	0.0s ~ 3600.0s	
P5-21	DO2 output delay time	Default	0.0s
	Setting Range	0.0s ~ 3600.0s	

These parameters are used to set the delay time of output terminals Y2R, relay 1, relay 2, Y1 and DO2 from status change to actual output.

P5-22	DO valid mode selection	Default	00000
	Setting Range	Unit's digit	Y2R valid mode
		0	Positive logic
		1	Negative logic
		Ten's digit	RELAY1 valid mode(0 ~ 1, same as Y2R)
		Hundred's digit	RELAY2 valid mode(0 ~ 1, same as Y2R)
		Thousand's digit	Y1 valid mode(0 ~ 1, same as Y2R)
		Ten thousand's digit	DO2 valid mode(0 ~ 1, same as Y2R)

It is used to set the logic of output terminals Y2R, relay 1, relay 2, Y1 and DO2.

0: Positive logic

The output terminal is valid when being connected with COM, and invalid when being disconnected from COM.

1: Negative logic

The output terminal is invalid when being connected with COM, and valid when being disconnected from COM

## Group P6 Start/Stop Control

P6-00	Start mode		Default	0
	Setting Range	0	Direct start	
		1	Rotational speed tracking restart	
		2	Pre-excited start (asynchronous motor)	

0: Direct start

- If the DC braking time is set to 0, the AC drive starts to run at the startup frequency.
- If the DC braking time is not 0, the AC drive performs DC braking first and then starts to run at the startup frequency. It is applicable to small-inertia load application where the motor is likely to rotate at startup.

1: Rotational speed tracking restart

The AC drive judges the rotational speed and direction of the motor first and then starts at the tracked frequency. Such smooth start has no impact on the rotating motor. It is applicable to the restart upon instantaneous power failure of large-inertia load. To ensure the performance of rotational speed tracking restart, set the motor parameters in group P1 correctly.

2: Pre-excited start (asynchronous motor)

It is valid only for asynchronous motor and used for building the magnetic field before the motor runs. For pre-excited current and pre-excited time, see parameters of P6-05 and P6-06.

- If the pre-excited time is 0, the AC drive cancels pre-excitation and starts to run at startup frequency.
- If the pre-excited time is not 0, the AC drive pre-excites first before startup, improving the dynamic response of the motor.

P6-01	Rotational speed		Default	0
	Setting Range	0	From frequency at stop	
		1	From zero speed	
		2	From maximum frequency	

To complete the rotational speed tracking process within the shortest time, select the proper mode in which the AC drive tracks the motor rotational speed.

0: From frequency at stop

It is the commonly selected mode.

1: From zero frequency

It is applicable to restart after a long time of power failure.

2: From the maximum frequency, it is applicable to the power-generating load.

## HV580 Series Frequency Inverter

P6-02	Rotational speed tracking speed	Default	20
	Setting Range	1 ~ 100	

In the rotational speed tracking restart mode, select the rotational speed tracking speed. The larger the value is, the faster the tracking is. However, too large value may cause unreliable tracking.

P6-03	Startup frequency	Default	0.00Hz
	Setting Range	0.00Hz ~ 10.00Hz	
P6-04	Startup frequency holding time	Default	0.0s
	Setting Range	0.0s ~ 100.0s	

To ensure the motor torque at AC drive startup, set a proper startup frequency. In addition, to build excitation when the motor starts up, the startup frequency must be held for a certain period.

The startup frequency (P6-03) is not restricted by the frequency lower limit. If the set target frequency is lower than the startup frequency, the AC drive will not start and stays in the standby state.

During switchover between forward rotation and reverse rotation, the startup frequency holding time is disabled. The holding time is not included in the acceleration time but in the running time of simple PLC.

Example 1:

P0-03 = 0      The frequency source is digital setting.

P0-08 = 2.00Hz      The digital setting frequency is 2.00Hz.

P6-03 = 5.00Hz      The startup frequency is 5.00Hz.

P6-04 = 2.0s      The startup frequency holding time is 2.0s.

In this example, the AC drive stays in the standby state and the output frequency is 0.00 Hz.

Example 2 :

P0-03 = 0      The frequency source is digital setting.

P0-08 = 10.00Hz      The digital setting frequency is 10.00 Hz.

P6-03 = 5.00Hz      The startup frequency is 5.00 Hz.

P6-04 = 2.0s      The startup frequency holding time is 2.0s.

In this example, the AC drive accelerates to 5.00 Hz, and then accelerates to the set frequency 10.00 Hz after 2s.

Startup DC braking is generally used during restart of the AC drive after the rotating motor stops.

Pre-excitation is used to make the AC drive build magnetic field for the asynchronous motor before startup to improve the responsiveness.

Startup DC braking is valid only for direct start (P6-00 = 0). In this case, the AC drive performs DC braking at the set startup DC braking current. After the startup DC braking time, the AC drive starts to run. If the startup DC braking time is 0, the AC drive starts directly without DC braking. The larger the startup DC braking current is, the larger the braking force is.



## HV580 Series Frequency Inverter

If the startup mode is pre-excited start (P6-00 = 3), the AC drive builds magnetic field based on the set pre-excited current. After the pre-excited time, the AC drive starts to run. If the pre-excited time is 0, the AC drive starts directly without pre-excitation.

The startup DC braking current or pre-excited current is a percentage relative to the base value.

P6-07	Acceleration/Deceleration mode	Default	0
	Setting Range	0	Linear acceleration/deceleration
		1	S-curve acceleration/deceleration A
		2	S-curve acceleration/deceleration B

It is used to set the frequency change mode during the AC drive start and stop process.

0: Linear acceleration/deceleration

The output frequency increases or decreases in linear mode. The HV580 provides four group of acceleration/deceleration time, which can be selected by using P4-00 to P4-08.

- 1: S-curve acceleration/deceleration A

The output frequency increases or decreases along the S curve. This mode is generally used in the applications where start and stop processes are relatively smooth, such as elevator and conveyor belt. P6-08 and P6-09 respectively define the time proportions of the start segment and the end segment.

- 2: S-curve acceleration/deceleration B

In this curve, the rated motor frequency  $f_b$  is always the inflexion point. This mode is usually used in applications where acceleration/deceleration is required at the speed higher than the rated frequency.

When the set frequency is higher than the rated frequency, the acceleration/deceleration time is:

$$t = \left( \frac{4}{9} \times \left( \frac{f}{f_b} \right)^2 + \frac{5}{9} \right) \times T$$

In the formula,  $f$  is the set frequency,  $f_b$  is the rated motor frequency and  $T$  is the acceleration time from 0 Hz to  $f_b$ .

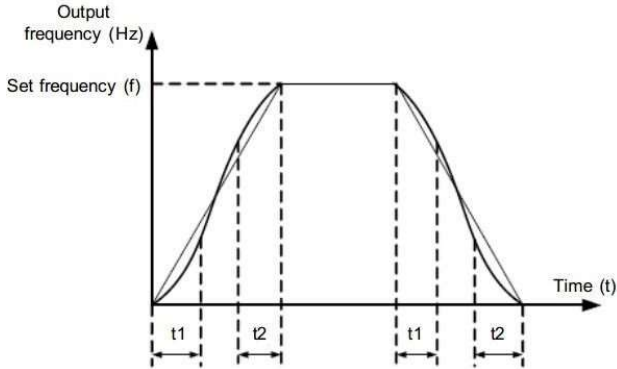

Figure 6-11 S-curve acceleration/deceleration A

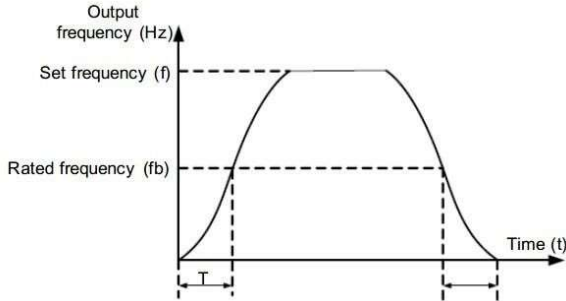

Figure 6-13 S-curve acceleration/deceleration B

P6-08	Time proportion of S-curve start segment	Default	30.0%
	Setting Range	0.0% ~ (100.0%-P6-09)	
P6-09	Time proportion of S-curve end segment	Default	30.0%
	Setting Range	0.0% ~ (100.0%-P6-08)	

These two parameters respectively define the time proportions of the start segment and the end segment of S-curve acceleration/deceleration. They must satisfy the requirement: P6-08 + P6-09 ≤ 100.0%.

In Figure 6-11, t1 is the time defined in P6-08, within which the slope of the output frequency change increases gradually. t2 is the time defined in P6-09, within which the slope of the output frequency change gradually decreases to 0. Within the time between t1 and t2, the slope of the output frequency change remains unchanged, that is, linear acceleration/deceleration.

P6-10	Stop mode	Default	0
	Setting Range	0	Decelerate to stop
		1	Coast to stop

**0: Decelerate to stop**

After the stop command is enabled, the AC drive decreases the output frequency according to the deceleration time and stops when the frequency decreases to zero.

**1: Coast to stop**

After the stop command is enabled, the AC drive immediately stops the output. The motor will coast to stop based on the mechanical inertia

P6-11	Initial frequency of stop DC braking	Default	0.00Hz
	Setting Range	0.00Hz ~ maximum frequency	
P6-12	Waiting time of stop DC braking	Default	0.0s
	Setting Range	0.0s ~ 36.0s	
P6-13	Stop DC braking current	Default	0%
	Setting Range	0% ~ 100%	
P6-14	Stop DC braking time	Default	0.0s
	Setting Range	0.0s ~ 36.0s	

**P6-11 (Initial frequency of stop DC braking)**

During the process of decelerating to stop, the AC drive starts DC braking when the running frequency is lower than the value set in P6-11.

**P6-12 (Waiting time of stop DC braking)**

When the running frequency decreases to the initial frequency of stop DC braking, the AC drive stops output for a certain period and then starts DC braking. This prevents faults such as overcurrent caused due to DC braking at high speed.

**P6-13 (Stop DC braking current)**

This parameter specifies the output current at DC braking and is a percentage relative to the base value.

- If the rated motor current is less than or equal to 80% of the rated AC drive current, the base value is the rated motor current.

- If the rated motor current is greater than 80% of the rated AC drive current, the base value is 80% of the rated AC drive current.

**P6-14 (Stop DC braking time)**

This parameter specifies the holding time of DC braking. If it is set to 0, DC braking is cancelled.

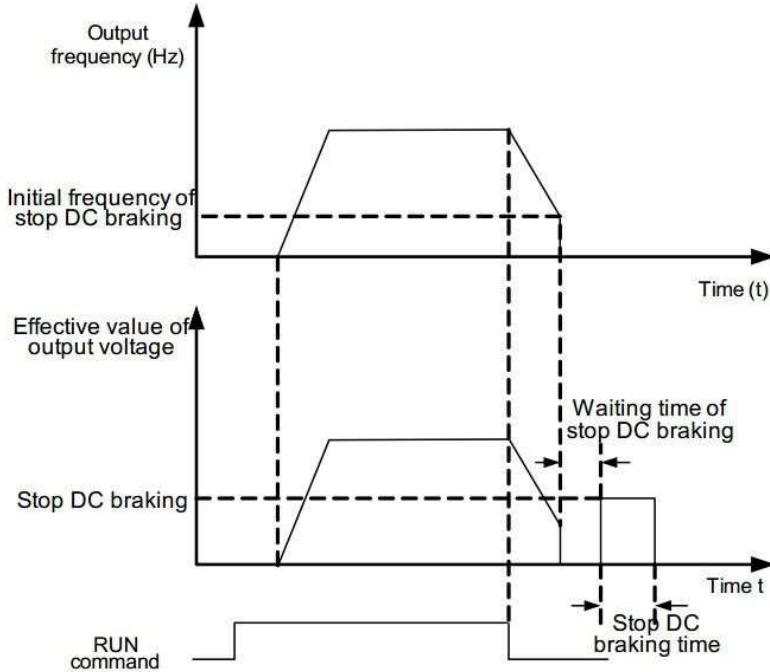

Figure 6-13 Stop DC braking process

P6-15	Brake use ratio	Default	100%
	Setting Range	0% ~ 100%	

It is valid only for the AC drive with internal braking unit and used to adjust the duty ratio of the braking unit. The larger the value of this parameter is, the better the braking result will be. However, too larger value causes great fluctuation of the AC drive bus voltage during the braking process.

### Group P7 Operation Panel and Display

P7-01	MF Key function selection	Default	0
	Setting Range	0	MF key disabled
		1	Switchover between operation panel control and remote command control (terminal or communication)
		2	Switchover between forward rotation
		3	Forward JOG
	4	Reverse JOG	

## HV580 Series Frequency Inverter

MF key refers to multifunctional key. You can set the function of the MF key by using this parameter. You can perform switchover by using this key both in stop or running state.

0: MF key disabled

1: Switchover between operation panel control and remote command control (terminal or communication).

You can perform switchover from the current command source to the operation panel control (local operation).

If the current command source is operation panel control, this key is invalid.

2: Switchover between forward rotation and reverse rotation

You can change the direction of the frequency reference by using the MF key. It is valid only when the current command source is operation panel control.

3: Forward JOG

You can perform forward JOG (FJOG) by using the MF key.

4: Reverse JOG

You can perform reverse JOG (FJOG) by using the MF key.

P7-02	STOP/RESET key function	Default	1															
	Setting Range	0	STOP/RESET key enabled only in operation panel															
		1	STOP/RESET key enabled in any operation mode															
P7-03	LED display running parameters 1	Default	1F															
	Setting Range	0000~ FFFF	<div style="text-align: center;"> <p>0000-FFFF</p> <table style="margin: auto; border-collapse: collapse;"> <tr> <td style="border: 1px solid black; padding: 2px;">7</td><td style="border: 1px solid black; padding: 2px;">6</td><td style="border: 1px solid black; padding: 2px;">5</td><td style="border: 1px solid black; padding: 2px;">4</td><td style="border: 1px solid black; padding: 2px;">3</td><td style="border: 1px solid black; padding: 2px;">2</td><td style="border: 1px solid black; padding: 2px;">1</td><td style="border: 1px solid black; padding: 2px;">0</td> </tr> <tr> <td colspan="8" style="text-align: center;"> </td> </tr> </table> </div> <p style="text-align: center; margin-top: 10px;">If a parameter needs to be displayed during the running, set the corresponding bit to 1, and set P7-03 to the hexadecimal equivalent of this binary number.</p>	7	6	5	4	3	2	1	0							
7	6	5	4	3	2	1	0											
P7-04	LED display running parameters 2	Default	0															

## HV580 Series Frequency Inverter

			<p style="text-align: center;">0000~FFFF</p> <div style="display: flex; justify-content: space-around;"> <div style="border: 1px solid black; padding: 2px;">7</div> <div style="border: 1px solid black; padding: 2px;">6</div> <div style="border: 1px solid black; padding: 2px;">5</div> <div style="border: 1px solid black; padding: 2px;">4</div> <div style="border: 1px solid black; padding: 2px;">3</div> <div style="border: 1px solid black; padding: 2px;">2</div> <div style="border: 1px solid black; padding: 2px;">1</div> <div style="border: 1px solid black; padding: 2px;">0</div> </div> <ul style="list-style-type: none"> <li>_____ PID feedback</li> <li>_____ PLC stage</li> <li>_____ Pulse setting frequency(kHz)</li> <li>_____ Running frequency2</li> <li>_____ Remaining running time</li> <li>_____ AI1 voltage before correction</li> <li>_____ AI2 voltage before correction</li> <li>_____ AI3 voltage before correction</li> </ul> <div style="display: flex; justify-content: space-around; margin-top: 10px;"> <div style="border: 1px solid black; padding: 2px;">15</div> <div style="border: 1px solid black; padding: 2px;">14</div> <div style="border: 1px solid black; padding: 2px;">13</div> <div style="border: 1px solid black; padding: 2px;">12</div> <div style="border: 1px solid black; padding: 2px;">11</div> <div style="border: 1px solid black; padding: 2px;">10</div> <div style="border: 1px solid black; padding: 2px;">9</div> <div style="border: 1px solid black; padding: 2px;">8</div> </div> <ul style="list-style-type: none"> <li>_____ Linear speed</li> <li>_____ Current power-on time (Hour)</li> <li>_____ Current running time(Minute)</li> <li>_____ Pulse setting frequency (Hz)</li> <li>_____ Communication setting value</li> <li>_____ Encoder feedback speed (Hz)</li> <li>_____ Main frequency X display (Hz)</li> <li>_____ Auxiliary frequency Y display (Hz)</li> </ul> <p style="margin-top: 20px;">If a parameter needs to be displayed during the running, set the corresponding bit to 1, and set P7-03 to the hexadecimal equivalent of this binary number.</p>
--	--	--	--

These two parameters are used to set the parameters that can be viewed when the AC drive is in the running state. You can view a maximum of 32 running state parameters that are displayed from the lowest bit of P7-03.

			<p style="text-align: center;">LED display stop parameters      Default      0</p> <p style="text-align: center;">0000~FFFF</p> <div style="display: flex; justify-content: space-around;"> <div style="border: 1px solid black; padding: 2px;">7</div> <div style="border: 1px solid black; padding: 2px;">6</div> <div style="border: 1px solid black; padding: 2px;">5</div> <div style="border: 1px solid black; padding: 2px;">4</div> <div style="border: 1px solid black; padding: 2px;">3</div> <div style="border: 1px solid black; padding: 2px;">2</div> <div style="border: 1px solid black; padding: 2px;">1</div> <div style="border: 1px solid black; padding: 2px;">0</div> </div> <ul style="list-style-type: none"> <li>_____ Set frequency (Hz)</li> <li>_____ Bus voltage (V)</li> <li>_____ DI input status</li> <li>_____ DO output status</li> <li>_____ AI1 voltage (V)</li> <li>_____ AI2 voltage (V)</li> <li>_____ AI3 voltage (V)</li> <li>_____ Count value</li> </ul> <div style="display: flex; justify-content: space-around; margin-top: 10px;"> <div style="border: 1px solid black; padding: 2px;">15</div> <div style="border: 1px solid black; padding: 2px;">14</div> <div style="border: 1px solid black; padding: 2px;">13</div> <div style="border: 1px solid black; padding: 2px;">12</div> <div style="border: 1px solid black; padding: 2px;">11</div> <div style="border: 1px solid black; padding: 2px;">10</div> <div style="border: 1px solid black; padding: 2px;">9</div> <div style="border: 1px solid black; padding: 2px;">8</div> </div> <ul style="list-style-type: none"> <li>_____ Length value</li> <li>_____ PLC stage</li> <li>_____ Load speed</li> <li>_____ PID setting</li> <li>_____ Pulse setting frequency (kHz)</li> <li>_____ Reserved</li> <li>_____ Reserved</li> <li>_____ Reserved</li> </ul> <p style="margin-top: 20px;">If a parameter needs to be displayed during the running, set the</p>
--	--	--	--

## HV580 Series Frequency Inverter

			corresponding bit to 1, and set P7-05 to the hexadecimal equivalent of this binary number.
--	--	--	--

P7-06	Load speed display coefficient	Default	1.0000
	Setting Range	0.0001 ~ 6.5000	

This parameter is used to adjust the relationship between the output frequency of the AC drive and the load speed. For details, see the description of P7-12.

P7-07	Heatsink temperature of inverter Module	Default	—
	Setting Range	0.0°C ~ 100.0°C	

It is used to display the insulated gate bipolar transistor (IGBT) temperature of the inverter module, and the IGBT overheat protection value of the inverter module depends on the model.

P7-08	Temporary software version	Default	—
	Setting Range	—	

It is used to display the temporary software version of the control board.

P7-09	Accumulative running time	Default	0 hour
	Setting Range	0h ~ 65535h	

It is used to display the accumulative running time of the AC drive. After the accumulative running time reaches the value set in P8-17, the terminal with the digital output function 12 becomes ON.

P7-10	Product number	Default	
	Setting Range	AC drive product number	
P7-11	Software version	Default	
	Setting Range	Software version of control board	
P7-12	Number of decimal places for load speed	Default	1
	Setting Range	0	0 decimal place
		1	1 decimal place
		2	2 decimal places
		3	3 decimal places

P7-12 is used to set the number of decimal places for load speed display. The following gives an example to explain how to calculate the load speed:

Assume that P7-06 (Load speed display coefficient) is 2.000 and P7-12 is 2 (2 decimal places). When the running frequency of the AC drive is 40.00 Hz, the load speed is  $40.00 \times 2.000 = 80.00$  (display of 2 decimal places).

If the AC drive is in the stop state, the load speed is the speed corresponding to the set frequency, namely,

## HV580 Series Frequency Inverter

"set load speed". If the set frequency is 50.00 Hz, the load speed in the stop state is  $50.00 \times 2.000 = 100.00$  (display of 2 decimal places).

P7-13	Accumulative power-on time	Default	—
	Setting Range	0 ~ 65535 hour	

It is used to display the accumulative power-on time of the AC drive since the delivery. If the time reaches the set power-on time (P8-17), the terminal with the digital output function 24 becomes ON.

P7-14	Accumulative power consumption	Default	-
	Setting Range	0 ~ 65535 kWh	

It is used to display the accumulative power consumption of the AC drive until now.

### Group P8 Auxiliary Functions

P8-00	JOG running frequency	Default	2.00Hz
	Setting Range	0.00Hz ~ maximum frequency	
P8-01	JOG acceleration time	Default	20.0s
	Setting Range	0.0s ~ 6500.0s	
P8-02	JOG deceleration time	Default	20.0s
	Setting Range	0.0s ~ 6500.0s	

These parameters are used to define the set frequency and acceleration/deceleration time of the AC drive when jogging.

The startup mode is "Direct start" (P6-00 = 0) and the stop mode is "Decelerate to stop" (P6-10 = 0) during jogging.

P8-03	Acceleration time 2	Default	Model dependent
	Setting Range	0. 0s ~ 6500.0s	
P8-04	Deceleration time 2	Default	Model dependent
	Setting Range	0. 0s ~ 6500.0s	
P8-05	Acceleration time 3	Default	Model dependent
	Setting Range	0. 0s ~ 6500.0s	
P8-06	Deceleration time 3	Default	Model dependent
	Setting Range	0. 0s ~ 6500.0s	
P8-07	Acceleration time 4	Default	Model dependent
	Setting Range	0. 0s ~ 6500.0s	
P8-08	Deceleration time 4	Default	Model dependent
	Setting Range	0. 0s ~ 500.0s	

The HV580 provides a total of four groups of acceleration/deceleration time, that is, the preceding three groups and the group defined by P0-17 and P0-18. Definitions of four groups are completely the same. You can switch over between the four groups of acceleration/deceleration time through different state combinations of X terminals. For more details, see the descriptions of P4-01 to P4-05.



### HV580 Series Frequency Inverter

P8-09	Jump frequency 1	Default	0.00Hz
	Setting Range	0.00Hz ~ maximum frequency	
P8-10	Jump frequency 2	Default	0.00Hz
	Setting Range	0.00 Hz ~ maximum frequency	
P8-11	Frequency jump amplitude	Default	0.00Hz
	Setting Range	0.00 ~ maximum frequency	

If the set frequency is within the frequency jump range, the actual running frequency is the jump frequency close to the set frequency. Setting the jump frequency helps to avoid the mechanical resonance point of the load. The HV580 supports two jump frequencies. If both are set to 0, the frequency jump function is disabled. The principle of the jump frequencies and jump amplitude is shown in the following figure.

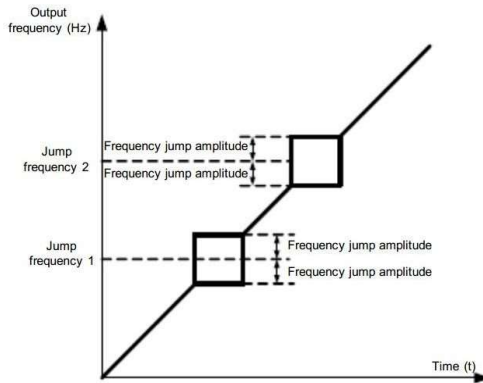

Figure 6-14 Principle of the jump frequencies and jump amplitude

P8-12	Forward/Reverse rotation dead-zone time	Default	0.0s
	Setting Range	0.0s ~ 3000.0s	

It is used to set the time when the output is 0 Hz at transition of the AC drive forward rotation and reverse rotation, as shown in the following figure.

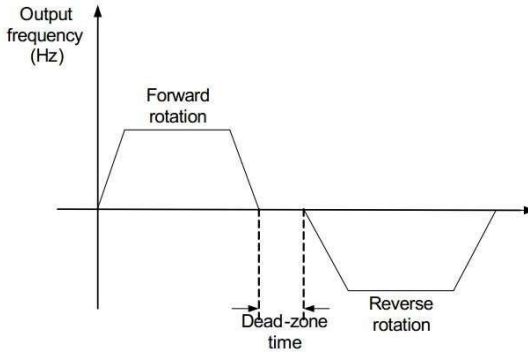

Figure 6-15 Forward/Reverse rotation dead-zone time

P8-13	Reverse control	Default	0
	Setting Range	0	Enabled
		1	Disabled

It is used to set whether the AC drive allows reverse rotation. In the applications where reverse rotation is prohibited, set this parameter to 1.

P8-14	Running mode when set frequency lower than frequency lower limit	Default	0
	Setting Range	0	Run at frequency lower limit
		1	Stop
		2	Run at zero speed

It is used to set the AC drive running mode when the set frequency is lower than the frequency lower limit. The HV580 provides three running modes to satisfy requirements of various applications.

P8-15	Droop control	Default	0.00Hz
	Setting Range	0.00Hz ~ 10.00Hz	

This function is used for balancing the workload allocation when multiple motors are used to drive the same load. The output frequency of the AC drives decreases as the load increases. You can reduce the workload of the motor under load by decreasing the output frequency for this motor, implementing workload balancing between multiple motors.

P8-16	Accumulative power-on time threshold	Default	0h
	Setting Range	0h ~ 65000h	

If the accumulative power-on time (P7-13) reaches the value set in this parameter, the corresponding DO terminal becomes ON.

For example, combining virtual DI/DO functions, to implement the function that the AC drive reports an alarm

## HV580 Series Frequency Inverter

when the actual accumulative power-on time reaches the threshold of 100 hours, perform the setting as follows:

- 1) Set virtual DI1 to user-defined fault 1: A1-00 = 44.
- 2) Set that the valid state of virtual DI1 is from virtual DO1: A1-05 = 0000.
- 3) Set virtual DO1 to power-on time reached: A1-11= 24.
- 4) Set the accumulative power-on time threshold to 100 h: P8-16 = 100 h.

Then, the AC drive reports Err27 when the accumulative power-on time reaches 100 hours.

P8-17	Accumulative running time threshold	Default	0h
	Setting Range	0h ~ 65000h	

It is used to set the accumulative running time threshold of the AC drive. If the accumulative running time (P7-09) reaches the value set in this parameter, the corresponding DO terminal becomes ON.

P8-18	Startup protection	Default	0
	Setting Range	0	No
		1	Yes

This parameter is used to set whether to enable the safety protection. If it is set to 1, the AC drive does not respond to the run command valid upon AC drive power-on (for example, an input terminal is ON before power-on). The AC drive responds only after the run command is cancelled and becomes valid again. In addition, the AC drive does not respond to the run command valid upon fault reset of the AC drive. The run protection can be disabled only after the run command is cancelled. In this way, the motor can be protected from responding to run commands upon power-on or fault reset in unexpected conditions.

P8-19	Frequency detection value(PDT1)	Default	50.00Hz
	Setting Range	0.00Hz ~ maximum frequency	
P8-20	Frequency detection hysteresis (FDT hysteresis 1)	Default	5.0%
	Setting Range	0.0% ~ 100.0% (FDT1 level)	

If the running frequency is higher than the value of P8-19, the corresponding DO terminal becomes ON. If the running frequency is lower than value of P8-19, the DO terminal goes OFF

These two parameters are respectively used to set the detection value of output frequency and hysteresis value upon cancellation of the output. The value of P8-20 is a percentage of the hysteresis frequency to the frequency detection value (P8-19).

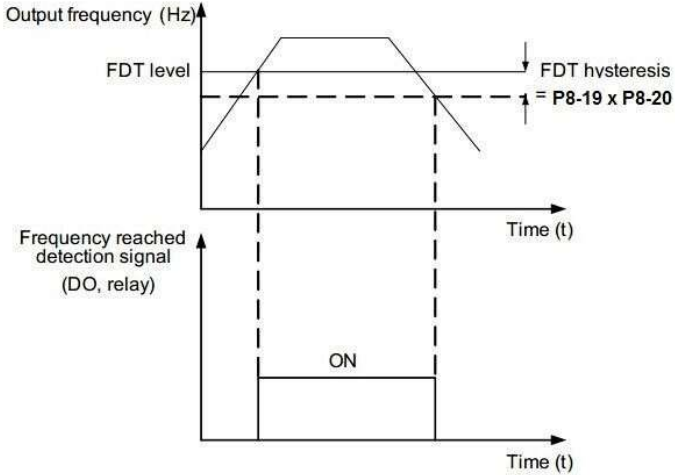
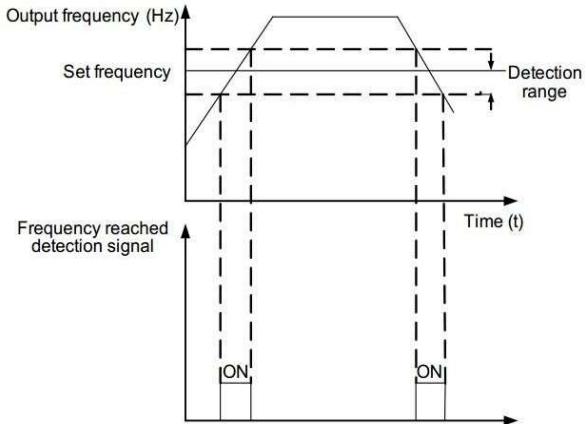

Figure 6-16 FDT level

P8-21	Detection range of frequency reached	Default	0.0%
	Setting Range	0.00 ~ 100%( maximum frequency )	

If the AC drive running frequency is within the certain range of the set frequency, the corresponding DO terminal becomes ON.

This parameter is used to set the range within which the output frequency is detected to reach the set frequency. The value of this parameter is a percentage relative to the maximum frequency. The detection range of frequency reached is shown in the following figure.



## HV580 Series Frequency Inverter

Figure 6-17 Detection range of frequency reached

P8-22	Jump frequency during acceleration/deceleration	Default	0
	Setting Range	0: Disabled; 1: Enabled	

It is used to set whether the jump frequencies are valid during acceleration/deceleration.

When the jump frequencies are valid during acceleration/deceleration, and the running frequency is within the frequency jump range, the actual running frequency will jump over the set frequency jump amplitude (rise directly from the lowest jump frequency to the highest jump frequency). The following figure shows the diagram when the jump frequencies are valid during acceleration/deceleration.

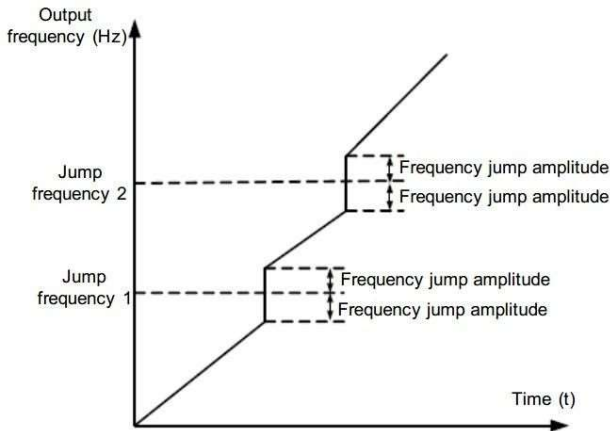

Figure 6-18 Diagram when the jump frequencies are valid during acceleration/deceleration

P8-25	Frequency switchover point between acceleration time 1 and acceleration time 2	Default	0.00Hz
	Setting Range	0.00Hz ~ maximum frequency	
P8-26	Frequency switchover point between deceleration time 1 and deceleration time 2	Default	0.00Hz
	Setting Range	0.00Hz ~ maximum frequency	

This function is valid when motor 1 is selected and acceleration/deceleration time switchover is not performed by means of X terminal. It is used to select different groups of acceleration/deceleration time based on the running frequency range rather than DI terminal during the running process of the AC drive.

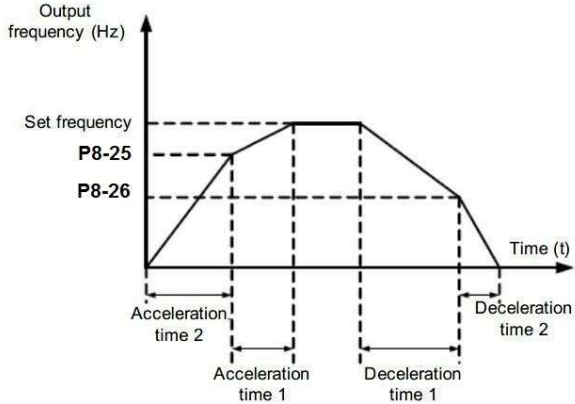

Figure 6-19 Acceleration/deceleration time switchovers

During acceleration, if the running frequency is smaller than the value of P8-25, acceleration time 2 is selected. If the running frequency is larger than the value of P8-25, acceleration time 1 is selected. During deceleration, if the running frequency is larger than the value of P8-26, deceleration time 1 is selected. If the running frequency is smaller than the value of P8-26, deceleration time 2 is selected.

P8-27	Terminal JOG preferred	Default	0
	Setting Range	0: Disabled; 1: Enabled	

It is used to set whether terminal JOG is preferred.

If terminal JOG is preferred, the AC drive switches to terminal JOG running state when there is a terminal JOG command during the running process of the AC drive.

P8-28	Frequency detection value (PDT2)	Default	50.00Hz
	Setting Range	0.00Hz ~ maximum frequency	
P8-29	Frequency detection hysteresis (FDT hysteresis 2)	Default	5.0%
	Setting Range	0.0% ~ 100.0% (PDT2 level)	

The frequency detection function is the same as FDT1 function. For details, refer to the descriptions of P8-19 and P8-20.

P8-30	Any frequency reaching detection value 1	Default	50.00Hz
	Setting Range	0.00Hz ~ maximum frequency	
P8-31	Any frequency reaching detection amplitude 1	Default	0.0%
	Setting Range	0.0% ~ 100.0%(maximum frequency)	
P8-32	Any frequency reaching detection value 2	Default	50.00Hz
	Setting Range	0.00Hz ~ maximum frequency	
P8-33	Any frequency reaching detection amplitude 2	Default	0.0%
	Setting Range	0.0% ~ 100.0%(maximum Frequency)	

## HV580 Series Frequency Inverter

If the output frequency of the AC drive is within the positive and negative amplitudes of the any frequency reaching detection value, the corresponding DO becomes ON.

The HV580 provides two groups of any frequency reaching detection parameters, including frequency detection value and detection amplitude, as shown in the following figure.

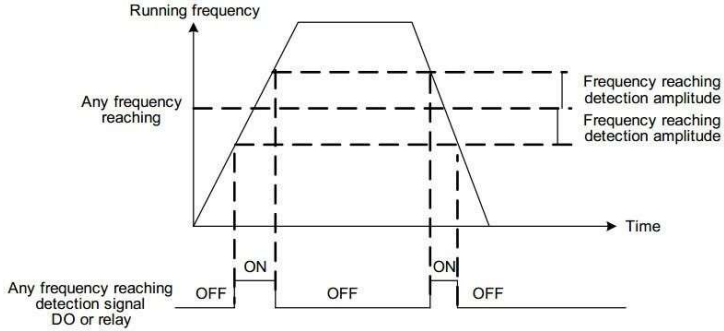

Figure 6-20 Any frequency reaching detection

P8-34	Zero current detection level	Default	5.0%
	Setting Range	0.0% ~ 300.0%( rated motor current)	
P8-35	Zero current detection delay time	Default	0.10s
	Setting Range	0.00s ~ 600.00s	

If the output current of the AC drive is equal to or less than the zero current detection level and the duration exceeds the zero current detection delay time, the corresponding DO becomes ON. The zero current detection is shown in the following figure.

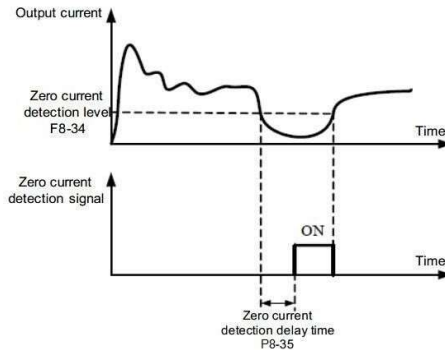

Figure 6-21 Zero current detection

P8-36	Output overcurrent threshold	Default	200.0%
	Setting Range	0.0%( no detection );0.1% ~ 300.0% (rated motor current)	
P8-37	Output overcurrent detection delay time	Default	0.00s
	Setting Range	0.00s ~ 600.00s	

If the output current of the AC drive is equal to or higher than the overcurrent threshold and the duration exceeds the detection delay time, the corresponding DO becomes ON. The output overcurrent detection function is shown in the following figure.

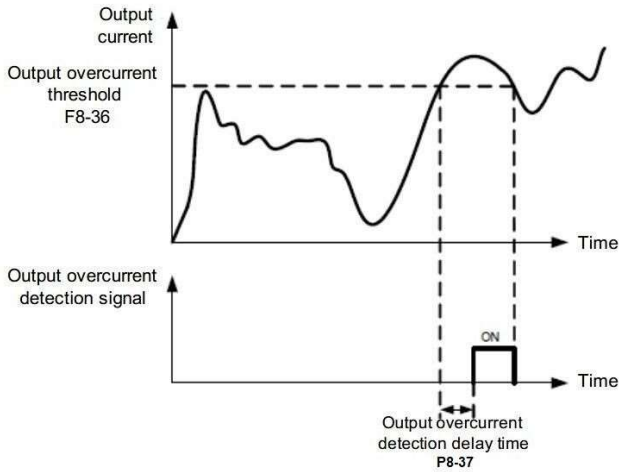

Figure 6-22 Output overcurrent detection

P8-38	Any current reaching 1	Default	100.0%
	Setting Range	0.0% ~ 300.0%( rated motor current )	
P8-39	Any current reaching 1 amplitude	Default	0.0%
	Setting Range	0.0% ~ 300.0%( rated motor current )	
P8-40	Any current reaching 2	Default	100.0%
	Setting Range	0.0% ~ 300.0%( rated motor current )	
P8-41	Any current reaching 2 amplitude	Default	0.0%
	Setting Range	0.0% ~ 300.0%( rated motor current )	



## HV580 Series Frequency Inverter

If the output current of the AC drive is within the positive and negative amplitudes of any current reaching detection value, the corresponding DO becomes ON.

The HV580 provides two groups of any current reaching detection parameters, including current detection value and detection amplitudes, as shown in the following figure.

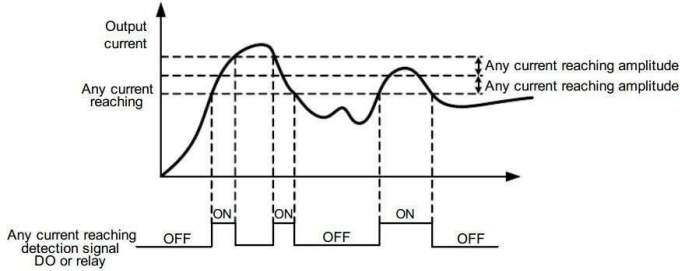

Figure 6-23 Any current reaching detection

P8-42	Timing function	Default	0
	Setting Range	0	Disabled
		1	Enabled
P8-43	Timing duration source	Default	0
	Setting Range	0	P8-44
		1	VS
		2	AS
		3	VS2
		(100% of analog input corresponds to the value of P8-44)	
P8-44	Timing duration	Default	0.0Min
	Setting Range	0.0Min ~ 6500.0Min	

These parameters are used to implement the AC drive timing function.

If P8-42 is set to 1, the AC drive starts to time at startup. When the set timing duration is reached, the AC drive stops automatically and meanwhile the corresponding DO becomes ON.

The AC drive starts timing from 0 each time it starts up and the remaining timing duration can be queried by U0-20.

The timing duration is set in P8-43 and P8-44, in unit of minute.

P8-45	VS input voltage lower limit	Default	3.10V
	Setting Range	0.00V ~ P8-46	
P8-46	VS input voltage upper limit	Default	6.80V
	Setting Range	P8-45 ~ 10.00V	

These two parameters are used to set the limits of the input voltage to provide protection on the AC drive.

## HV580 Series Frequency Inverter

When the VS input is larger than the value of P8-46 or smaller than the value of P8-45, the corresponding DO becomes ON, indicating that VS input exceeds the limit.

P8-47	Module temperature threshold	Default	75°C
	Setting Range	0.00V ~ P8-46	

When the heatsink temperature of the AC drive reaches the value of this parameter, the corresponding DO becomes ON, indicating that the module temperature reaches the threshold.

P8-48	Cooling fan control	Default	0
	Setting Range	0 : Fan working during running; 1: Fan working continuously	

It is used to set the working mode of the cooling fan. If this parameter is set to 0, the fan works when the AC drive is in running state. When the AC drive stops, the cooling fan works if the heatsink temperature is higher than 40°C, and stops working if the heatsink temperature is lower than 40°C.

If this parameter is set to 1, the cooling fan keeps working after power-on.

P8-49	Wakeup frequency	Default	0.00Hz
	Setting Range	Dormant frequency (P8-51) to maximum frequency (P0-10)	
P8-50	Wakeup delay time	Default	0.0s
	Setting Range	0.0s ~ 6500.0s	
P8-51	Dormant frequency	Default	0.00Hz
	Setting Range	0.00Hz ~wakeup frequency (P8-49)	
P8-52	Dormant delay time	Default	0.0s
	Setting Range	0.0s ~ 6500.0s	

These parameters are used to implement the dormant and wakeup functions in the water supply application.

When the AC drive is in running state, the AC drive enters the dormant state and stops automatically after the dormant delay time (P8-52) if the set frequency is lower than or equal to the dormant frequency (P8-51).

When the AC drive is in dormant state and the current running command is effective, the AC drives starts up after the wakeup delay time (P8-50) if the set frequency is higher than or equal to the wakeup frequency (P8-49).

Generally, set the wakeup frequency equal to or higher than the dormant frequency. If the wakeup frequency and dormant frequency are set to 0, the dormant and wakeup functions are disabled.

When the dormant function is enabled, if the frequency source is PID, whether PID operation is performed in the dormant state is determined by PA-28. In this case, select PID operation enabled in the stop state (PA-28 = 1).

## HV580 Series Frequency Inverter

P8-53	Current running time reached	Default	0.0Min
	Setting Range	0.0Min ~ 6500.0Min	

If the current running time reaches the value set in this parameter, the corresponding DO becomes ON, indicating that the current running time is reached.

### Group P9 Fault and Protection

P9-00	Motor overload protection selection	Default	1
	Setting Range	0	Disabled
		1	Enabled
P9-01	Motor overload protection gain	Default	1
	Setting Range	0.20 ~ 10.00	

P9-00 = 0

The motor overload protective function is disabled. The motor is exposed to potential damage due to overheating. A thermal relay is suggested to be installed between the AC drive and the motor.

P9-00 = 1

The AC drive judges whether the motor is overloaded according to the inverse time-lag curve of the motor overload protection.

The inverse time-lag curve of the motor overload protection is:

$220\% \times P9-01 \times \text{rated motor current}$  (if the load remains at this value for one minute, the AC drive reports motor overload fault), or  $150\% \times P9-01 \times \text{rated motor current}$  (if the load remains at this value for 60 minutes, the AC drive reports motor overload fault)

Set P9-01 properly based on the actual overload capacity. If the value of P9-01 is set too large, damage to the motor may result because the motor overheats but the AC drive does not report the alarm.

P9-02	Motor overload warning coefficient	Default	80%
	Setting Range	50% ~ 100%	

This function is used to give a warning signal to the control system via DO before motor overload rotection.

This parameter is used to determine the percentage, at which pre-warning is performed before motor overload.

The larger the value is, the less advanced the pre-warning will be.

When the accumulative output current of the AC drive is greater than the value of the overload inverse time-lag curve multiplied by P9-02, the DO terminal on the AC drive allocated with function 6 (Motor overload pre-warning) becomes ON.

## HV580 Series Frequency Inverter

P9-03	Overvoltage stall gain	Default	0
	Setting Range	0 (no stall overvoltage)~ 100	
P9-04	Overvoltage stall protective voltage	Default	130%
	Setting Range	120% ~ 150%	

When the DC bus voltage exceeds the value of P9-04 (Overvoltage stall protective voltage) during deceleration of the AC drive, the AC drive stops deceleration and keeps the present running frequency. After the bus voltage declines, the AC drive continues to decelerate.

P9-03 (Overvoltage stall gain) is used to adjust the overvoltage suppression capacity of the AC drive. The larger the value is, the greater the overvoltage suppression capacity will be.

In the prerequisite of no overvoltage occurrence, set P9-03 to a small value. For small-inertia load, the value should be small. Otherwise, the system dynamic response will be slow. For large-inertia load, the value should be large. Otherwise, the suppression result will be poor and an overvoltage fault may occur.

If the overvoltage stall gain is set to 0, the overvoltage stall function is disabled.

P9-05	Overcurrent stall gain	Default	20
	Setting Range	0 ~ 100	
P9-06	Overcurrent stall protective current	Default	150%
	Setting Range	100% ~ 200%	

When the output current exceeds the overcurrent stall protective current during acceleration/deceleration of the AC drive, the AC drive stops acceleration/deceleration and keeps the present running frequency. After the output current declines, the AC drive continues to accelerate/decelerate.

P9-05 (Overcurrent stall gain) is used to adjust the overcurrent suppression capacity of the AC drive. The larger the value is, the greater the overcurrent suppression capacity will be. In the prerequisite of no overcurrent occurrence, set P9-05 to a small value.

For small-inertia load, the value should be small. Otherwise, the system dynamic response will be slow. For large-inertia load, the value should be large. Otherwise, the suppression result will be poor and overcurrent fault may occur.

If the overcurrent stall gain is set to 0, the overcurrent stall function is disabled.

P9-07	Short-circuit to ground upon power-on	Default	1
	Setting Range	0: Disabled; 1: Enabled	

It is used to determine whether to check the motor is short-circuited to ground at power-on of the AC drive. If this function is enabled, the AC drive's UVW will have voltage output a while after power-on.

### HV580 Series Frequency Inverter

P9-09	Fault auto reset times	Default	0
	Setting Range	0 ~ 20	

It is used to set the times of fault auto resets if this function is used. After the value is exceeded, the AC drive will remain in the fault state.

P9-10	DO action during fault auto reset	Default	0
	Setting Range	0: Not act; 1: Act	

It is used to decide whether the DO acts during the fault auto reset if the fault auto reset function is selected.

P9-11	Time interval of fault auto reset	Default	1.0s
	Setting Range	0.1s ~ 100.0s	

It is used to set the waiting time from the alarm of the AC drive to fault auto reset.

P9-12	Input phase loss protection/contactor energizing protection selection	Default	11
	Setting Range	Unit's digit: Input phase loss protection Ten's digit: Contactor energizing 0: Disabled 1: Enabled	

It is used to determine whether to perform input phase loss or contactor energizing protection.

For every voltage class, the HV580 AC drives of powers equal to or greater than those listed in the preceding table provide the function of input phase loss or contactor energizing protection. The HV580 AC drives below the power listed in the table do not have the function no matter whether P9-12 is set to 0 or 1.

P9-13	Output phase loss protection selection	Default	1
	Setting Range	0: Disabled 1: Enabled	

It is used to determine whether to perform output phase loss protection.

P9-14	1st fault type	0 ~ 99
P9-15	2nd fault type	
P9-16	3rd (latest) fault type	

It is used to record the types of the most recent three faults of the AC drive. 0 indicates no fault. For possible causes and solution of each fault, refer to Chapter 8.

P9-17	Frequency upon 3rd fault	It displays the frequency when the latest fault occurs.
P9-18	Current upon 3rd fault	It displays the current when the latest fault occurs.

### HV580 Series Frequency Inverter

P9-19	Bus voltage upon 3rd fault	It displays the bus voltage when the latest fault Occurs.																				
P9-20	Digital Input status upon 3rd fault	<p>It displays the status of all DI terminals when the latest fault occurs. The sequence is as follows:</p> <table border="1" style="margin-left: auto; margin-right: auto;"> <tr> <td>BIT9</td><td>BIT8</td><td>BIT7</td><td>BIT6</td><td>BIT5</td><td>BIT4</td><td>BIT3</td><td>BIT2</td><td>BIT1</td><td>BIT0</td> </tr> <tr> <td>DI0</td><td>DI9</td><td>DI8</td><td>DI7</td><td>DI6</td><td>DI5</td><td>DI4</td><td>DI3</td><td>DI2</td><td>DI1</td> </tr> </table> <p>If the X terminal is ON, the setting is 1. If the X terminal is OFF, the setting is 0. The value is the equivalent decimal number converted from the X terminal status.</p>	BIT9	BIT8	BIT7	BIT6	BIT5	BIT4	BIT3	BIT2	BIT1	BIT0	DI0	DI9	DI8	DI7	DI6	DI5	DI4	DI3	DI2	DI1
BIT9	BIT8	BIT7	BIT6	BIT5	BIT4	BIT3	BIT2	BIT1	BIT0													
DI0	DI9	DI8	DI7	DI6	DI5	DI4	DI3	DI2	DI1													
P9-21	Output terminal status upon 3rd fault	<p>It displays the status of all output terminals when the latest fault occurs. The sequence is as follows:</p> <table border="1" style="margin-left: auto; margin-right: auto;"> <tr> <td>BIT4</td><td>BIT3</td><td>BIT2</td><td>BIT1</td><td>BIT0</td> </tr> <tr> <td>DO2</td><td>DO1</td><td>REL2</td><td>REL1</td><td>FMP</td> </tr> </table> <p>If an output terminal is ON, the setting is 1. If the output terminal is OFF, the setting is 0. The value is the equivalent decimal number converted from the X terminal statuses.</p>	BIT4	BIT3	BIT2	BIT1	BIT0	DO2	DO1	REL2	REL1	FMP										
BIT4	BIT3	BIT2	BIT1	BIT0																		
DO2	DO1	REL2	REL1	FMP																		
P9-22	AC drive status upon 3rd	Reserved																				
P9-23	Power-on time upon 3rd Fault	It displays the present power-on time when the latest fault occurs.																				
P9-24	Running time upon 3rd Fault	It displays the present running time when the latest fault occurs.																				
P9-27	Frequency upon 2nd fault	Same as P9-17 ~ P9-24																				
P9-28	Current upon 2nd fault																					
P9-29	Bus voltage upon 2nd fault																					
P9-30	X terminal status upon 2nd fault																					
P9-31	Output terminal status																					
P9-32	Frequency upon 2nd fault																					
P9-33	Current upon 2nd fault																					

### HV580 Series Frequency Inverter

P9-34	Bus voltage upon 2nd fault	Same as P9-17 ~ P9-24
P9-37	X terminal status upon 1st fault	
P9-38	Current upon 1st fault	
P9-39	Bus voltage upon 3rd fault	
P9-40	X terminal status upon 1st fault	
P9-41	Output terminal status	
P9-42	AC Drive status upon 1 <sup>st</sup> fault	
P9-43	Output terminal status upon 1st fault	
P9-44	Frequency upon 1st fault	

P9-47	Fault protection action selection 1		Default	00000
	Setting Range	Unit's digit	Motor overload (Err11)	
		0	Coast to stop	
		1	Stop according to the stop mode	
		2	Continue to run	
		Ten's digit	Power input phase loss (Err12) (Same as unit's digit)	
		Hundred's digit	Power output phase loss (Err13) (Same as unit's digit)	
		Thousand's digit	External equipment fault (Err15) (Same as unit's digit)	
		Ten thousand's digit	Communication fault (Err16) (Same as unit's digit)	

P9-48	Fault protection action selection 2		Default	00000
	Setting Range	Unit's digit	Encoder fault (Err20)	
		0	Coast to stop	
		1	Switch over to V/F control, stop according to the stop mode	

HV580 Series Frequency Inverter

		2	Switch over to V/F control, continue to run
		Ten's digit	EEPROM read-write fault (Err21)
		0	Coast to stop
		1	Stop according to the stop mode
		Hundred's digit	Reserved
		Thousand's digit	Motor overheat (Err25) Same as unit's digit in P9-47
		Ten thousand's digit	Accumulative running time reached (Err26) Same as unit's digit in P9-47
P9-49	Setting Range	Fault protection action selection 3	Default    00000
		Unit's digit	User-defined fault 1(Err27) Same as unit's digit in P9-47
		Ten's digit	User-defined fault 2(Err28) Same as unit's digit in P9-47
		Hundred's digit	Accumulative power-on time reached (Err29) Same as unit's digit in P9-47
		Thousand's digit	Load becoming 0 (Err30)
		0	Coast to stop
		1	Stop according to the stop mode
		2	Continue to run at 7% of rated motor frequency and resume to the set frequency if the load Recovers
		Ten thousand's digit	PID feedback lost during running (Err31) Same as unit's digit in P9-47



### HV580 Series Frequency Inverter

P9-50	Fault protection action selection 4		Default	00000
	Setting Range	Unit's digit	Too large speed deviation, (Err42) Same as unit's digit in P9-47	
		Ten's digit	Motor over-speed (Err43) Same as unit's digit in P9-47	
		Hundred's digit	Initial position fault (Err51) Same as unit's digit in P9-47	
		Thousand's digit	Speed feedback fault (Err52) Same as unit's digit in P9-47	
		Ten thousand's digit	Reserved	

If "Coast to stop" is selected, the AC drive displays Err\*\* and directly stops.

- If "Stop according to the stop mode" is selected, the AC drive displays A\*\* and stops according to the stop mode. After stop, the AC drive displays Err\*\*.
- If "Continue to run" is selected, the AC drive continues to run and displays A\*\*. The running frequency is set in P9-54.

P9-54	Frequency selection for continuing to run upon fault		Default	0
	Setting Range	0	Current running frequency	
		1	Set frequency	
		2	Frequency upper limit	
		3	Frequency lower limit	
P9-55	Backup frequency upon abnormality	Default	100.0%	
	Setting Range	0.0% ~ 100.0%(maximum frequency)		

If a fault occurs during the running of the AC drive and the handling of fault is set to "Continue to run", the AC drive displays A\*\* and continues to run at the frequency set in P9-54.

The setting of F9-55 is a percentage relative to the maximum frequency.

## HV580 Series Frequency Inverter

P9-56	Type of motor temperature sensor	Default	0
	Setting Range	0	No temperature sensor
		1	PT100
		2	PT1000
P9-57	Motor overheat protection threshold	Default	110°C
	Setting Range	0°C ~ 200°C	
P9-58	Motor overheat warning threshold	Default	90°C
	Setting Range	0°C ~ 200°C	

The signal of the motor temperature sensor needs to be connected to the optional I/O extension card. VS2 on the extension card can be used for the temperature signal input.

The motor temperature sensor is connected to VS2 and PGND of the extension card. The VS2 terminal of the HV580 supports both PT100 and PT1000. Set the sensor type correctly during the use. You can view the motor temperature via C-34.

If the motor temperature exceeds the value set in P9-57, the AC drive reports an alarm and acts according to the selected fault protection action.

If the motor temperature exceeds the value set in P9-58, the DO terminal on the AC drive allocated with function 39 (Motor overheat warning) becomes ON.

P9-59	Action selection at instantaneous power failure	Default	0
	Setting Range	0	Invalid
		1	Decelerate
		2	Decelerate to stop
P9-60	Action pause judging voltage at instantaneous power failure	Default	90.0%
	Setting Range	80.0% ~ 100.0%	
P9-61	Voltage rally judging time at instantaneous power failure	Default	0.50s
	Setting Range	0.00s ~ 100.00s	

### HV580 Series Frequency Inverter

P9-62	Action judging voltage at instantaneous power failure	Default	80.0%
	Setting Range	60.0% ~ 100.0% ( standard bus voltage )	

Upon instantaneous power failure or sudden voltage dip, the DC bus voltage of the AC drive reduces. This function enables the AC drive to compensate the DC bus voltage reduction with the load feedback energy by reducing the output frequency so as to keep the AC drive running continuously.

- If P9-59 = 1, upon instantaneous power failure or sudden voltage dip, the AC drive decelerates. Once the bus voltage resumes to normal, the AC drive accelerates to the set frequency. If the bus voltage remains normal for the time exceeding the value set in P9-61, it is considered that the bus voltage resumes to normal.
- If P9-59 = 2, upon instantaneous power failure or sudden voltage dip, the AC drive decelerates to stop.

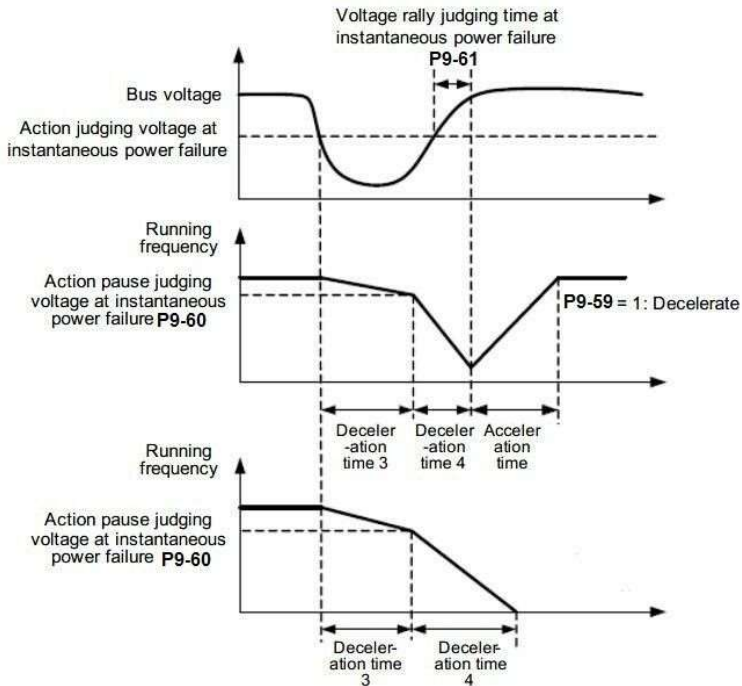

Figure 6-24 AC drive action diagram upon instantaneous power failure

### HV580 Series Frequency Inverter

P9-63	Protection upon load becoming 0		Default	0
	Setting Range	0	Disabled	
		1	Enabled	
P9-64	Detection level of load becoming 0		Default	10.0%
	Setting Range		0.0% ~ 100.0% (rated motor current)	
P9-65	Detection time of load becoming 0		Default	1.0s
	Setting Range		0.0s ~ 60.0s	

If protection upon load becoming 0 is enabled, when the output current of the AC drive is lower than the detection level (P9-64) and the lasting time exceeds the detection time (P9-65), the output frequency of the AC drive automatically declines to 7% of the rated frequency. During the protection, the AC drive automatically accelerates to the set frequency if the load resumes to normal.

P9-67	Over-speed detection value	Default	20.0%
	Setting Range	0.0% ~ 50.0%( maximum frequency)	
P9-68	Over-speed detection time	Default	1.0s
	Setting Range	0.0s ~ 60.0s	

This function is valid only when the AC drive runs in the CLVC mode. If the actual motor rotational speed detected by the AC drive exceeds the maximum frequency and the excessive value is greater than the value of P9-67 and the lasting time exceeds the value of P9-68, the AC drive reports Err43 and acts according to the selected fault protection action.

If the over-speed detection time is 0.0s, the over-speed detection function is disabled.

P9-69	Detection value of too large speed deviation	Default	20.0%
	Setting Range	0.0% ~ 50.0%(maximum frequency)	
P9-70	Detection time of too large speed deviation	Default	5.0s
	Setting Range	0.0s ~ 60.0s	

This function is valid only when the AC drive runs in the CLVC mode. If the AC drive detects the deviation between the actual motor rotational speed detected by the AC drive and the set frequency is greater than the value of P9-69 and the lasting time exceeds the value of P9-70, the AC drive reports Err42 and according to the selected fault protection action.

If P9-70 (Detection time of too large speed deviation) is 0.0s, this function is disabled.

**Group PA: Process Control PID Function**

PID control is a general process control method. By performing proportional, integral and differential operations on the difference between the feedback signal and the target signal, it adjusts the output frequency and constitutes a feedback system to stabilize the controlled counter around the target value.

It is applied to process control such as flow control, pressure control and temperature control. The following figure shows the principle block diagram of PID control.

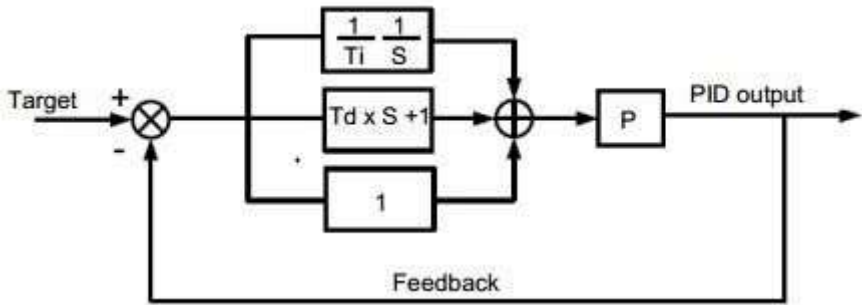

Figure 6-25 Principle block diagram of PID control

PA-00	PID setting source	Default	0
	Setting Range	0	PA-01 Setting
		1	VS
		2	AS
		3	VS2
		4	PULSE Pulse (X5)
		5	Communication
6	Multi-reference		
PA-01	PID digital setting	Default	50.0%
	Setting range	0.0% ~ 100.0%	

PA-00 is used to select the channel of target process PID setting. The PID setting is a relative value and ranges from 0.0% to 100.0%. The PID feedback is also a relative value.

The purpose of PID control is to make the PID setting and PID feedback equal.

### HV580 Series Frequency Inverter

PA-02	PID Feedback source		Default	0
	Setting range		0	VS
			1	AS
			2	VS2
			3	VS – AS
			4	PULSE Pulse ( X5 )
			5	Communication
			6	VS+AS
			7	MAX( VS <sub>i</sub>  , AS )
	8	MIN ( VS <sub>i</sub>  , AS )		

This parameter is used to select the feedback signal channel of process PID.

The PID feedback is a relative value and ranges from 0.0% to 100.0%.

PA-03	PID action direction		Default	0
	Setting range		0	Forward action
			1	Reverse action

0: Forward action

When the feedback value is smaller than the PID setting, the AC drive's output frequency rises. For example, the winding tension control requires forward PID action.

• 1: Reverse action

When the feedback value is smaller than the PID setting, the AC drive's output frequency reduces. For example, the unwinding tension control requires reverse PID action.

Note that this function is influenced by the DI function 35 "Reverse PID action direction".

PA-04	PID setting		Default	1000
	feedback range			
	Setting range		0 ~ 65535	

This parameter is a non-dimensional unit. It is used for PID setting display (C-15) and PID feedback display (C-16).

Relative value 100% of PID setting feedback corresponds to the value of FA-04. If FA-04 is set to 2000 and

PID setting is 100.0%, the PID setting display (C-15) is 2000.PID

PA-05	Proportional gain Kp1		Default	20.0
	Setting range		0.0 ~ 100.0	
PA-06	Integral time Ti1		Default	2.00s
	Setting range		0.01s ~ 10.00s	
PA-07	Differential timeTd1		Default	0.000s

## HV580 Series Frequency Inverter

	Setting range	0.00 ~ 10.000
--	---------------	---------------

### PA-05 (Proportional gain Kp1)

It decides the regulating intensity of the PID regulator. The higher the Kp1 is, the larger the regulating intensity is. The value 100.0 indicates when the deviation between PID feedback and PID setting is 100.0%, the adjustment amplitude of the PID regulator on the output frequency reference is the maximum frequency.

- PA-06 (Integral time Ti1)

It decides the integral regulating intensity. The shorter the integral time is, the larger the regulating intensity is. When the deviation between PID feedback and PID setting is 100.0%, the integral regulator performs continuous adjustment for the time set in PA-06. Then the adjustment amplitude reaches the maximum frequency.

- PA-07 (Differential time Td1)

It decides the regulating intensity of the PID regulator on the deviation change. The longer the differential time is, the larger the regulating intensity is. Differential time is the time within which the feedback value change reaches 100.0%, and then the adjustment amplitude reaches the maximum frequency.

PA-08	Cut-off frequency of PID	Default	2.00Hz
	Setting range	0. 00 ~ Max frequency	

In some situations, only when the PID output frequency is a negative value (AC drive reverse rotation), PID setting and PID feedback can be equal. However, too high reverse rotation frequency is prohibited in some applications, and FA-08 is used to determine the reverse rotation frequency upper limit.

PA-09	PID deviation limit	Default	0.0%
	Setting range	0. 0% ~ 100.0%	

If the deviation between PID feedback and PID setting is smaller than the value of PA-09, PID control stops. The small deviation between PID feedback and PID setting will make the output frequency stabilize, effective for some closed-loop control applications.

PA-10	PID deviation limit	Default	0.10%
	Setting range	0. 00% ~ 100.00%	

It is used to set the PID differential output range. In PID control, the differential operation may easily cause system oscillation. Thus, the PID differential regulation is restricted to a small range.

PA-11	PID setting change time	Default	0.00s
	Setting range	0.00s ~ 650.00s	

## HV580 Series Frequency Inverter

The PID setting change time indicates the time required for PID setting changing from 0.0% to 100.0%. The PID setting changes linearly according to the change time, reducing the impact caused by sudden setting change on the system.

PA-12	PID feedback filter time	Default	0.00s
	Setting range	0.00s ~ 60.00s	
PA-13	PID output filter time	Default	0.00s
	Setting range	0.00s ~ 60.00s	

PA-12 is used to filter the PID feedback, helping to reduce interference on the feedback but slowing the response of the process closed-loop system.

PA-13 is used to filter the PID output frequency, helping to weaken sudden change of the AC drive output frequency but slowing the response of the process closed-loop system.

PA-15	Proportional gain Kp2	Default	20.0
	Setting range	0.0 ~ 100.0	
PA-16	Integral time Ti2	Default	2.00s
	Setting range	0.01s ~ 10.00s	
PA-17	Differential time Td2	Default	0.000s
	Setting range	0.00 ~ 10.000	
PA-18	PID parameter switchover condition	Default	0
	Setting range	0	No switchover
		1	Switchover via DI
		2	Automatic switchover
PA-19	PID parameter switchover deviation 1	Default	20.0%
	Setting range	0.0% ~ PA-20	
PA-20	PID parameter switchover deviation 2	Default	80.0%
	Setting range	PA-19 ~ 100.0%	

In some applications, PID parameters switchover is required when one group of PID parameters cannot satisfy the requirement of the whole running process.

These parameters are used for switchover between two groups of PID parameters. Regulator parameters PA-15 to PA-17 are set in the same way as PA-05 to PA-07.

The switchover can be implemented either via a DI terminal or automatically implemented based on the deviation.

If you select switchover via a DI terminal, the DI must be allocated with function 43 "PID parameter



switchover". If the DI is OFF, group 1 (PA-05 to PA-07) is selected. If the DI is ON, group 2 (PA-15 to PA-17) is selected.

If you select automatic switchover, when the absolute value of the deviation between PID feedback and PID setting is smaller than the value of PA-19, group 1 is selected. When the absolute value of the deviation between PID feedback and PID setting is higher than the value of PA-20, group 2 is selected. When the deviation is between PA-19 and PA-20, the PID parameters are the linear interpolated value of the two groups of parameter values.

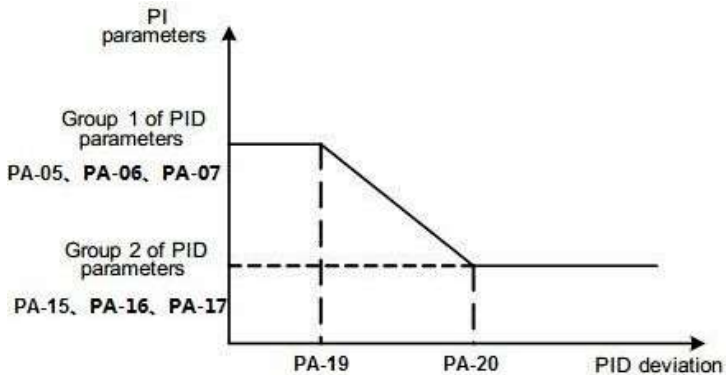

Figure 6-26 PID parameters switchover

PA-21	PID initial value	Default	0.0%
	Setting range	0.0% ~ 100.0%	
PA-22	PID initial value holding time	Default	0.00s
	Setting range	0.00s ~ 650.00s	

When the AC drive starts up, the PID starts closed-loop algorithm only after the PID output is fixed to the PID initial value (PA-21) and lasts the time set in PA-22.

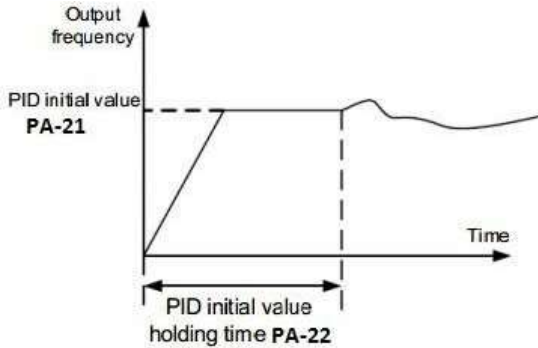

Figure 6-27 PID initial value function

PA-23	Maximum deviation between two PID outputs in forward direction	Default	1.00%
	Setting range	0.00% ~ 100.00%	
PA-24	Maximum deviation between two PID outputs in reverse direction	Default	1.00%
	Setting range	0.00% ~ 100.00%	

This function is used to limit the deviation between two PID outputs (2 ms per PID output) to suppress the rapid change of PID output and stabilize the running of the AC drive.

PA-23 and PA-24 respectively correspond to the maximum absolute value of the output deviation in forward direction and in reverse direction.

PA-25	PID integral property		Default	00
	Setting range	Unit's digit	Integral separated	
		0	Invalid	
		1	Valid	
		Ten's digit	Whether to stop integral operation when the output reaches the limit	
		0	Continue integral operation	
1	Stop integral operation			

- Integral separated

If it is set to valid, , the PID integral operation stops when the DI allocated with function 38 "PID integral pause" is ON In this case, only proportional and differential operations take effect.

If it is set to invalid, integral separated remains invalid no matter whether the DI allocated with function 38 "PID integral pause" is ON or not.

- Whether to stop integral operation when the output reaches the limit

If "Stop integral operation" is selected, the PID integral operation stops, which may help to reduce the PID overshoot.

PA-26	Detection value of PID	Default	0.0%
	Setting range	0.0%: Not judging feedback loss; 0.1% ~ 100.0%	
PA-27	Detection time of PID	Default	0.0s
	Setting range	0.0s ~ 20.0s	

These parameters are used to judge whether PID feedback is lost.

If the PID feedback is smaller than the value of PA-26 and the lasting time exceeds the value of PA-27, the AC drive reports Err31 and acts according to the selected fault protection action.

PA-28	PID operation at stop	Default	0
	Setting range	0	No PID operation at stop
		1	PID operation at stop

It is used to select whether to continue PID operation in the state of stop. Generally, the PID operation stops when the AC drive stops.

## Group PB: Swing Frequency, Fixed Length and Count

The swing frequency function is applied to the textile and chemical fiber fields and the applications where traversing and winding functions are required.

The swing frequency function indicates that the output frequency of the AC drive swings up and down with the set frequency as the center. The trace of running frequency at the time axis is shown in the following figure.

The swing amplitude is set in PB-00 and PB-01. When PB-01 is set to 0, the swing amplitude is 0 and the swing frequency does not take effect.

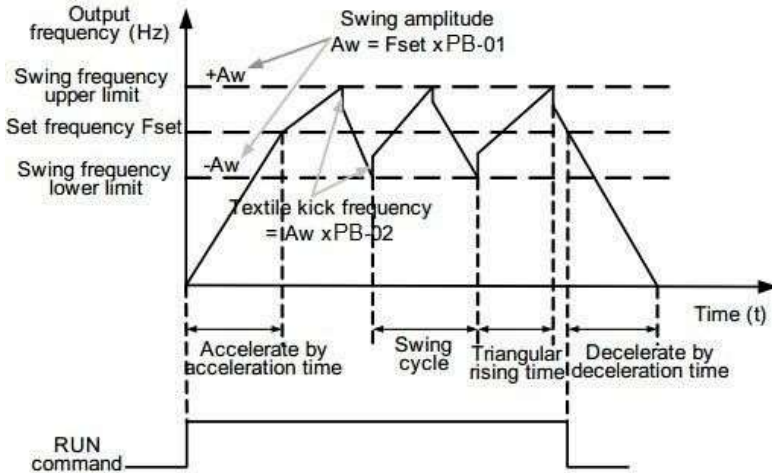

Figure 6-28 Swing frequency control

PB-00	Swing frequency setting mode	Default	0
	Setting range	0	Relative to the central frequency
		1	Relative to the maximum frequency

This parameter is used to select the base value of the swing amplitude.

- 0: Relative to the central frequency (P0-07 frequency source selection)  
It is variable swing amplitude system. The swing amplitude varies with the central frequency (set frequency).
- 1: Relative to the maximum frequency (P0-10 maximum output frequency)  
It is fixed swing amplitude system. The swing amplitude is fixed.

PB-01	Swing frequency amplitude	Default	0.0%
	Setting range	0.0% ~ 100.0%	
PB-02	Jump frequency amplitude	Default	0.0%
	Setting range	0.0% ~ 50.0%	

This parameter is used to determine the swing amplitude and jump frequency amplitude.

The swing frequency is limited by the frequency upper limit and frequency lower limit.

- If relative to the central frequency (PB-00 = 0), the actual swing amplitude AW is the calculation result of P0-07 (Frequency source selection) multiplied by PB-01.
- If relative to the maximum frequency (PB-00 = 1), the actual swing amplitude AW is the calculation result of

## HV580 Series Frequency Inverter

P0-10 (Maximum frequency) multiplied by PB-01.

Jump frequency = Swing amplitude AW x PB-02 (Jump frequency amplitude).

- If relative to the central frequency (PB-00 = 0), the jump frequency is a variable value.
- If relative to the maximum frequency (PB-00 = 1), the jump frequency is a fixed value.

The swing frequency is limited by the frequency upper limit and frequency lower limit.

PB-03	Swing frequency cycle	Default	10.0s
	Setting range	0.0s ~ 3000.0s	
PB-04	Triangular wave rising time coefficient	Default	50.0%
	Setting range	0.0% ~ 100.0%	

PB-03 specifies the time of a complete swing frequency cycle.

PB-04 specifies the time percentage of triangular wave rising time to PB-03 (Swing frequency cycle).

- Triangular wave rising time = PB-03 (Swing frequency cycle) x PB-04 (Triangular wave rising time coefficient, unit: s)

- Triangular wave falling time = PB-03 (Swing frequency cycle) x (1 – PB-04 Triangular wave rising time coefficient, unit: s)

PB-05	Setting Length	Default	1000m
	Setting range	0m ~ 65535m	
PB-06	Actual Length	Default	0m
	Setting range	0m ~ 65535m	
PB-07	Pulse/meter	Default	100.0
	Setting range	0.1 ~ 6553.5	

The preceding parameters are used for fixed length control.

The length information is collected by DI terminals. PB-06 (Actual length) is calculated by dividing the number of pulses collected by the DI terminal by PB-07 (Number of pulses each meter).

When the actual length PB-06 exceeds the set length in PB-05, the DO terminal allocated with function 10 (Length reached) becomes ON.

During the fixed length control, the length reset operation can be performed via the DI terminal allocated with function 28. For details, see the descriptions of P4-00 to P4-09.

Allocate corresponding DI terminal with function 27 (Length count input) in applications. If the pulse frequency is high, DI5 must be used.

PB-08	Set count value	Default	1000
	Setting range	1 ~ 65535	
PB-09	Designated count value	Default	1000
	Setting range	1 ~ 65535	

## HV580 Series Frequency Inverter

The count value needs to be collected by DI terminal. Allocate the corresponding DI terminal with function 25 (Counter input) in applications. If the pulse frequency is high, DI5 must be used.

When the count value reaches the set count value (PB-08), the DO terminal allocated with function 8 (Set count value reached) becomes ON. Then the counter stops counting.

When the counting value reaches the designated counting value (PB-09), the DO terminal allocated with function 9 (Designated count value reached) becomes ON. Then the counter continues to count until the set count value is reached.

PB-09 should be equal to or smaller than PB-08.

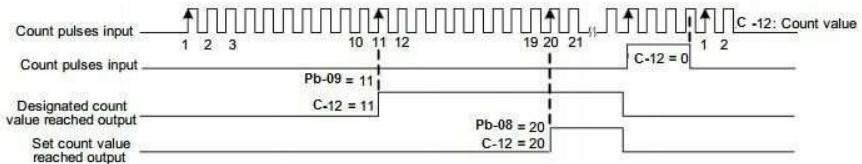

Figure 6-29 Reaching the set count value and designated count value

### Group PC: Multi-Reference and Simple PLC Function

The HV580 multi-reference has many functions. Besides multi-speed, it can be used as the setting source of the V/F separated voltage source and setting source of process PID. In addition, the multi-reference is relative value. The simple PLC function is different from the HV580 user programmable function. Simple PLC can only complete simple combination of multi-reference, while the user programmable function is more practical. For details, see the descriptions of group.

PC-00	Multi-reference 0	Default	0.0%
	Setting range	-100.0% ~ 100.0%	
PC-01	Multi-reference 1	Default	0.0%
	Setting range	-100.0% ~ 100.0%	
PC-02	Multi-reference 2	Default	0.0%
	Setting range	-100.0% ~ 100.0%	
PC-03	Multi-reference 3	Default	0.0%
	Setting range	-100.0% ~ 100.0%	
PC-04	Multi-reference 4	Default	0.0%
	Setting range	-100.0% ~ 100.0%	
PC-05	Multi-reference 5	Default	0.0%
	Setting range	-100.0% ~ 100.0%	
PC-06	Multi-reference 6	Default	0.0%
	Setting range	-100.0% ~ 100.0%	

### HV580 Series Frequency Inverter

PC-07	Multi-reference 7	Default	0.0%
	Setting range	-100.0% ~ 100.0%	
PC-08	Multi-reference 8	Default	0.0%
	Setting range	-100.0% ~ 100.0%	
PC-09	Multi-reference 9	Default	0.0%
	Setting range	-100.0% ~ 100.0%	
PC-10	Multi-reference 10	Default	0.0Hz
	Setting range	-100.0% ~ 100.0%	
PC-11	Multi-reference 11	Default	0.0%
	Setting range	-100.0% ~ 100.0%	
PC-12	Multi-reference 12	Default	0.0%
	Setting range	-100.0% ~ 100.0%	
PC-13	Multi-reference 13	Default	0.0%
	Setting range	-100.0% ~ 100.0%	
PC-14	Multi-reference 14	Default	0.0%
	Setting range	-100.0% ~ 100.0%	
PC-15	Multi-reference 15	Default	0.0%
	Setting range	-100.0% ~ 100.0%	

Multi-reference can be the setting source of frequency, V/F separated voltage and process PID. The multi-reference is relative value and ranges from -100.0% to 100.0%.

As frequency source, it is a percentage relative to the maximum frequency. As V/F separated voltage source, it is a percentage relative to the rated motor voltage. As process PID setting source, it does not require conversion.

Multi-reference can be switched over based on different states of DI terminals. For details, see the descriptions of group P4.

PC-16	Simple PLC running mode	Default	0
	Setting range	0	Stop after the AC drive runs one cycle
		1	Keep final values after the AC drive runs
		2	Repeat after the AC drive runs one cycle

- 0: Stop after the AC drive runs one cycle

The AC drive stops after running one cycle, and will not start up until receiving another command.

- 1: Keep final values after the AC drive runs one cycle

The AC drive keeps the final running frequency and direction after running one cycle.

- 2: Repeat after the AC drive runs one cycle

The AC drive automatically starts another cycle after running one cycle, and will not stop until receiving the

stop command.

Simple PLC can be either the frequency source or V/F separated voltage source.

When simple PLC is used as the frequency source, whether parameter values of PC-00 to PC-15 are positive or negative determines the running direction. If the parameter values are negative, it indicates that the AC drive runs in reverse direction.

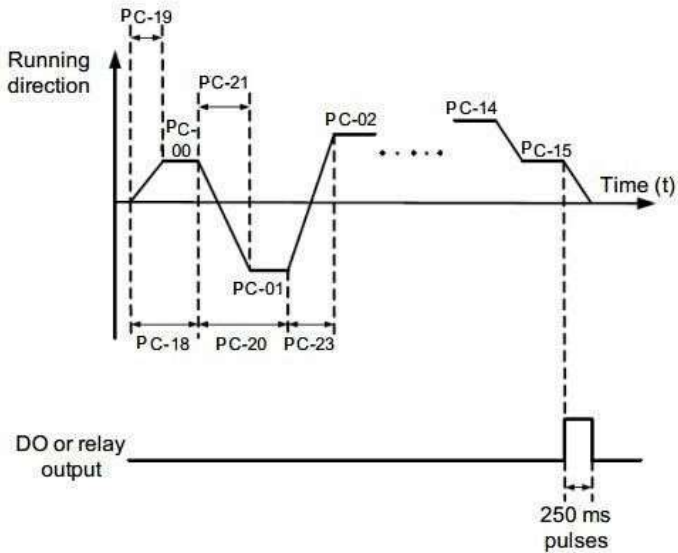

Figure 6-32 Simple PLC when used as frequency source

PC-17	Simple PLC retentive selection	Default	00
	Setting range	Unit's digit	Retentive upon power failure
		0	No
		1	Yes
		Ten's digit	Retentive upon stop
	0	No	
1	Yes		

PLC retentive upon power failure indicates that the AC drive memorizes the PLC running moment and running frequency before power failure and will continue to run from the memorized moment after it is powered on again. If the unit's digit is set to 0, the AC drive restarts the PLC process after it is powered on again.

PLC retentive upon stop indicates that the AC drive records the PLC running moment and running frequency



HV580 Series Frequency Inverter

upon stop and will continue to run from the recorded moment after it starts up again. If the ten's digit is set to 0, the AC drive restarts the PLC process after it starts up again.

PC-18	Running time of simple PLC	Default	0.0s(h)
	Setting range	0.0s(h) ~ 6553.5s(h)	
PC-19	Acceleration/deceleration time of simple PLC reference 0	Default	0
	Setting range	0 ~ 3	
PC-20	Running time of simple PLC reference 1	Default	0.0s(h)
	Setting range	0.0s(h) ~ 6553.5s(h)	
PC-21	Acceleration/deceleration time of simple PLC reference 1	Default	0
	Setting range	0 ~ 3	
PC-22	Running time of simple PLC reference 2	Default	0.0s(h)
	Setting range	0.0s(h) ~ 6553.5s(h)	
PC-23	Acceleration/deceleration time of simple	Default	0
	Setting range	0 ~ 3	
PC-24	Running time of simple PLC reference 3	Default	0.0s(h)
	Setting range	0.0s(h) ~ 6553.5s(h)	
PC-25	Acceleration/deceleration time of simple PLC reference 3	Default	0
	Setting range	0 ~ 3	
PC-26	Running time of simple PLC reference 4	Default	0.0s(h)
	Setting range	0.0s(h) ~ 6553.5s(h)	
PC-27	Acceleration/deceleration time of simple PLC reference 4	Default	0
	Setting range	0 ~ 3	
PC-28	Running time of simple PLC reference 5	Default	0.0s(h)

HV580 Series Frequency Inverter

	Setting range	0.0s(h) ~ 6553.5s(h)	
PC-29	Acceleration/deceleration time of simple PLC reference 5	Default	0
	Setting range	0 ~ 3	
PC-30	Running time of simple PLC reference 6	Default	0.0s(h)
	Setting range	0.0s(h) ~ 6553.5s(h)	
PC-31	Acceleration/deceleration time of simple PLC reference 6	Default	0
	Setting range	0 ~ 3	
PC-32	Running time of simple PLC reference 7	Default	0.0s(h)
	Setting range	0.0s(h) ~ 6553.5s(h)	
PC-33	Acceleration/deceleration time of simple PLC reference 7	Default	0
	Setting range	0 ~ 3	
PC-34	Running time of simple PLC reference 8	Default	0.0s(h)
	Setting range	0.0s(h) ~ 6553.5s(h)	
PC-35	Acceleration/deceleration time of simple PLC reference 8	Default	0
	Setting range	0 ~ 3	
PC-36	Running time of simple PLC reference 9	Default	0.0s(h)
	Setting range	0.0s(h) ~ 6553.5s(h)	
PC-37	Acceleration/deceleration time of simple PLC reference 9	Default	0
	Setting range	0 ~ 3	
PC-38	Running time of simple PLC reference 10	Default	0.0s(h)
	Setting range	0.0 s(h) ~ 6553.5s(h)	

HV580 Series Frequency Inverter

PC-39	Acceleration/deceleration time of simple PLC reference 10	Default	0
	Setting range	0 ~ 3	
PC-40	Running time of simple PLC reference 11	Default	0.0s(h)
	Setting range	0.0s(h) ~ 6553.5s(h)	
PC-41	Acceleration/deceleration time of simple PLC reference 11	Default	0
	Setting range	0 ~ 3	
PC-42	Running time of simple PLC reference 12	Default	0.0s(h)
	Setting range	0.0s(h) ~ 6553.5s(h)	
PC-43	Acceleration/deceleration time of simple PLC reference 12	Default	0
	Setting range	0 ~ 3	
PC-44	Running time of simple PLC reference 13	Default	0.0s(h)
	Setting range	0.0s(h) ~ 6553.5s(h)	
PC-45	Acceleration/deceleration time of simple PLC reference 13	Default	0
	Setting range	0 ~ 3	
PC-46	Running time of simple PLC reference 14	Default	0.0s(h)
	Setting range	0.0s(h) ~ 6553.5s(h)	
PC-47	Acceleration/deceleration time of simple PLC reference 14	Default	0
	Setting range	0 ~ 3	
PC-48	Running time of simple PLC reference 15	Default	0.0s(h)
	Setting range	0.0s(h) ~ 6553.5s(h)	
PC-49	Acceleration/deceleration time of simple PLC reference 15	Default	0

## HV580 Series Frequency Inverter

	Setting range	0 ~ 3	
PC-50	Time unit of simple PLC running	Default	0
	Setting range	0	S (Second)
		1	H (Hours)

	Reference 0 source	Default	0
PC-51	Setting range	0	Set by PC-00
		1	VS
		2	AS
		3	VS2
		4	PULSE Pulse
		5	PID
		6	Set by preset frequency (P0-08),

It determines the setting channel of reference 0. You can perform convenient switchover between the setting channels. When multi-reference or simple PLC is used as frequency source, the switchover between two frequency sources can be realized easily.

### Group PD: Communication parameters

Please refer to the "HV580 communication protocol".

### Group PP: User's password

PP-00	User's password	Default	0
	Setting range	0 ~ 65535	

If it is set to any non-zero number, the password protection function is enabled. After a password has been set and taken effect, you must enter the correct password in order to enter the menu. If the entered password is incorrect you cannot view or modify parameters.

If PP-00 is set to 00000, the previously set user password is cleared, and the password protection function is disabled.

	Restore default	Default	0
PP-01	Setting range	0	No option
		1	Restore factory settings except motor
		2	Clear records
		4	Restore user backup parameters
		501	Back up current user parameters

1: Restore default settings except motor parameters

If PP-01 is set to 1, most function codes are restored to the default settings except motor parameters, frequency reference resolution (P0-22), fault records, accumulative running time (P7-09), accumulative power-on time (P7-13) and accumulative power consumption (P7-14).

2: Clear records

If PP-01 is set to 2, the fault records, accumulative running time (P7-09), accumulative power-on time (P7-13) and accumulative power consumption P7-14) are cleared.

501: Back up current user parameters

If PP-01 is set to 501, the current parameter settings are backed up, helping you to restore the setting if incorrect parameter setting is performed.

4: Restore user backup parameters

If PP-01 is set to 4, the previous backup user parameters are restored.

PP-02	AC drive parameter display property		Default	11
	Setting range	Unit's digit	Group U display selection	
		0	No display	
		1	Display	
		Ten's digit	Group A display selection	
		0	No display	
		1	Display	
PP-03	Individualized parameter display property		Default	00
	Setting range	Unit's digit	User-defined parameter display selection	
		0	No display	
		1	Display	
		Ten's digit	User-modified parameter display selection	
		0	No display	
		1	Display	

The setting of parameter display mode aims to facilitate you to view different types of parameters based on actual requirements. The HV580 provides the following three parameter display modes.

## HV580 Series Frequency Inverter

Parameter Name	Description
AC drive parameter display	Display function codes of the AC drive in sequence of P0 to PF, A0 to AF and C Group.
User-defined parameter display	Display a maximum of 32 user-defined parameters included in group PE.
User-modified parameter display	Display the parameters that are modified.

If one digit of PP-03 is set to 1, you can switch over to different parameter display modes by pressing key QUICK. By default, the AC drive parameter display mode is used.

The display codes of different parameter types are shown in the following table.

Parameter Display Mode	Display
AC drive parameter	- b A S E
User-defined parameter	- U S E r
User-modified parameter	- - [ - -

The HV580 provides display of two types of individualized parameters: user-defined parameters and user-modified parameters.

- You-defined parameters are included in group PE. You can add a maximum of 32 parameters, convenient for commissioning.

In user-defined parameter mode, symbol "u" is added before the function code. For example, P1-00 is displayed as uP1-00.

- You-modified parameters are grouped together, convenient for on-site troubleshooting.

In you-modified parameter mode, symbol "c" is added before the function code. For example, P1-00 is displayed as cP1-00.

PP-04	Parameter modification		Default	0
	Setting range	0	Modifiable	
		1	Not modifiable	

It is used to set whether the parameters are modifiable to avoid mal-function. If it is set to 0, all parameters are modifiable. If it is set to 1, all parameters can only be viewed.

### Group A0: Torque Control and Restricting Parameters

A0-00	Speed/Torque control selection		Default	0
	Setting range	0	Speed control	
		1	Torque Control	

It is used to select the AC drive's control mode: speed control or torque control.

## HV580 Series Frequency Inverter

The HV580 provides DI terminals with two torque related functions, function 29 (Torque control prohibited) and function 46 (Speed control/Torque control switchover). The two DI terminals need to be used together with A0-00 to implement speed control/torque control switchover.

If the DI terminal allocated with function 46 (Speed control/Torque control switchover) is OFF, the control mode is determined by A0-00. If the DI terminal allocated with function 46 is ON, the control mode is reverse to the value of A0-00.

However, if the DI terminal with function 29 (Torque control prohibited) is ON, the AC drive is fixed to run in the speed control mode.

0-01	Torque setting source in torque control	Default	0
	Setting range	0	Digital Setting (A0-03)
		1	VS
		2	AS
		3	VS2
		4	PULSE Pulse (X5)
		5	Communication setting
		6	MIN(VS,AS)
7	MAX(VS,AS)		
A0-03	Torque digital setting in torque control	Default	150.0%
	Setting range	-200.0% ~ 200.0%	

A0-01 is used to set the torque setting source. There are a total of eight torque setting sources.

The torque setting is a relative value. 100.0% corresponds to the AC drive's rated torque.

The setting range is -200.0% to 200.0%, indicating the AC drive's maximum torque is twice of the AC drive's rated torque. A0-01 is used to select torque setting; there are 8 types of torque setting modes.

When torque Setting use mode1~7, communication, analog input, Pulse input100% to A0-03.

A0-05	Forward maximum frequency in torque control	Default	50.00Hz
	Setting range	0.00Hz ~Max frequency (P0-10)	
A0-06	Reverse maximum frequency in torque control	Default	50.00Hz
	Setting range	0.00Hz ~Max frequency (P0-10)	

## HV580 Series Frequency Inverter

Two parameters are used to set the maximum frequency in forward or reverse rotation in torque control mode. In torque control, if the load torque is smaller than the motor output torque, the motor's rotational speed will rise continuously. To avoid runaway of the mechanical system, the motor maximum rotating speed must be limited in torque control.

You can implement continuous change of the maximum frequency in torque control dynamically by controlling the frequency upper limit.

A0-07	Acceleration time in torque control	Default	0.00s
	Setting range	0.00s ~ 65000s	
A0-08	Deceleration time in torque control	Default	0.00s
	Setting range	0.00s ~ 65000s	

In torque control, the difference between the motor output torque and the load torque determines the speed change rate of the motor and load. The motor rotational speed may change quickly and this will result in noise or too large mechanical stress. The setting of acceleration/deceleration time in torque control makes the motor rotational speed change softly.

However, in applications requiring rapid torque response, set the acceleration/deceleration time in torque control to 0.00s. For example, two AC drives are connected to drive the same load. To balance the load allocation, set one AC drive as master in speed control and the other as slave in torque control. The slave receives the master's output torque as the torque command and must follow the master rapidly. In this case, the acceleration/deceleration time of the slave in torque control is set to 0.0s.

### Group C Monitor

C parameter set is used to monitor the inverter running state information, the customer can see through the panel, in order to convenient for debugging, also can be read by the communication parameter set value, to be used for PC monitor. Among them, 31 C - 00 ~ C - is the P7-03 and P7-04 defined in the operation and stop monitoring parameters. Specific parameters function code, name and smallest unit see table 6-1

Table 6-1 C Set parameter table



HV580 Series Frequency Inverter

Function code	Name	Smallest unit	Address
C-00	Running frequency (Hz)	0.01Hz	7000H
C-01	Set frequency (Hz)	0.01Hz	7001H
C-02	Bus voltage (V)	0.1V	7002H
C-03	Output voltage (V)	1V	7003H
C-04	Output current (A)	0.01A	7004H
C-05	Output power (kW)	0.1kW	7005H
C-06	Output torque (%)	0.1%	7006H
C-07	X DI state	1	7007H
C-08	DO DO state	1	7008H
C-09	VS voltage (V)	0.01V	7009H
C-10	AS voltage (V) / current (mA)	0.01V/0.01mA	700AH
C-11	VS2 voltage (V)	0.01V	700BH
C-12	Count value	1	700CH
C-13	Length value	1	700DH
C-14	Load speed	1	700EH
C-15	PID setting	1	700FH
C-16	PID feedback	1	7010H
C-17	PLC stage	1	7011H
C-18	Input pulse frequency (Hz)	0.01kHz	7012H
C-19	Feedback speed (Hz)	0.01Hz	7013H
C-20	Remaining running time	0.1Min	7014H
C-21	VS voltage before correction	0.001V	7015H
C-22	AS voltage (V) / current (mA) before correction	0.001V/0.01mA	7016H
C-23	VS2 voltage before correction	0.001V	7017H
C-24	Linear speed	1m/Min	7018H
C-25	Accumulative power-on time	1Min	7019H
C-26	Accumulative running time	0.1Min	701AH
C-27	PULSE input frequency	1Hz	701BH
C-28	Communication setting value	0.01%	701CH
C-29	Encoder feedback speed	0.01Hz	701DH
C-30	Main frequency X	0.01Hz	701EH
C-31	Auxiliary frequency Y	0.01Hz	701FH
C-32	Viewing any register address value	1	7020H
C-33	Synchronous motor rotor position	0.1°	7021H
C-34	Motor temperature	1°C	7022H
C-35	Target torque (%)	0.1%	7023H
C-36	Resolver position	1	7024H

## HV580 Series Frequency Inverter

C-37	Power factor angle	0.1°	7025H
C-38	ABZ position	1	7026H
C-39	Target voltage upon V/F separation	1V	7027H
C-40	Output voltage upon V/F separation	1V	7028H
C-41	X DI state visual display	1	7029H
C-42	DO state visual display	1	702AH
C-43	X DI function state visual display 1 (function 01-40)	1	702BH
C-44	X DI function state visual display 2 (function 41- 80)	1	702CH
C-45	Fault information	1	702DH

# Chapter 7 Maintenance and Troubleshooting

## 7.1 Routine Repair and Maintenance of the HV580

### 7.1.1 Routine Maintenance

The influence of the ambient temperature, humidity, dust and vibration will cause the aging of the devices in the AC drive, which may cause potential faults or reduce the service life of the AC drive. Therefore, it is necessary to carry out routine and periodic maintenance.

Routine maintenance involves checking:

- Whether the motor sounds abnormally during running
- Whether the motor vibrates excessively during running
- Whether the installation environment of the AC drive changes.
- Whether the AC drive's cooling fan works normally
- Whether the AC drive overheats

Routine cleaning involves:

- Keep the AC drive clean all the time.
- Remove the dust, especially metal powder on the surface of the AC drive, to prevent the dust from entering the AC drive.
- Clear the oil stain on the cooling fan of the AC drive.

### 7.1.2 Periodic Inspection

Perform periodic inspection in places where inspection is difficult.

Periodic inspection involves:

Check and clean the air duct periodically.

Check whether the screws become loose.

Check whether the AC drive is corroded.

Check whether the wiring terminals show signs of arcing;

Main circuit insulation test

Prompt: Before measuring the insulating resistance with mega meter (500 VDC mega meter recommended), disconnect the main circuit from the AC drive. Do not use the insulating resistance meter to test the insulation of the control circuit. The high voltage test need not be performed again because it has been completed before delivery.

### 7.1.3 Replacement of Vulnerable Components

The vulnerable components of the AC drive are cooling fan and filter electrolytic capacitor.

Their service life is related to the operating environment and maintenance status. Generally, the service life is shown as follows:

Component	Service Life	Possible Damage Reason	Judging Criteria
Fan	2 to 3 years	<ul style="list-style-type: none"> <li>• Bearing worn</li> <li>• Blade aging</li> </ul>	<ul style="list-style-type: none"> <li>• Whether there is crack on the blade</li> <li>• Whether there is abnormal vibration noise upon startup</li> </ul>
Electrolytic capacitor	4 to 5 years	<ul style="list-style-type: none"> <li>• Input power supply in poor quality</li> <li>• High ambient temperature</li> <li>• Frequent load jumping</li> <li>• Electrolytic aging</li> </ul>	<ul style="list-style-type: none"> <li>• Whether there is liquid leakage.</li> <li>• Whether the safe valve has projected.</li> <li>• Measure the static capacitance.</li> <li>• Measure the insulating resistance.</li> </ul>

### 7.1.4 Storage of the AC Drive

For storage of the AC drive, pay attention to the following two aspects:

- 1) Pack the AC drive with the original packing box provided by HNC Electric.
- 2) Long-term storage degrades the electrolytic capacitor. Thus, the AC drive must be energized once every 2 years, each time lasting at least 5 hours. The input voltage must be increased slowly to the rated value with the regulator.

## 7.2 Warranty Agreement

- 1) Free warranty only applies to the AC drive itself.
- 2) HNC Electric will provide 18-month warranty (starting from the leave-factory date as indicated on the barcode) for the failure or damage under normal use conditions. If the equipment has been used for over 18 months, reasonable repair expenses will be charged.
- 3) Reasonable repair expenses will be charged for the damages due to the following causes:
  - Improper operation without following the instructions
  - Fire, flood or abnormal voltage.
  - Using the AC drive for non-recommended function
- 4) The maintenance fee is charged according to HNC Electric's uniform standard. If there is an agreement, the agreement prevails.

## 7.3 Faults and Solutions

The HV580 provides a total of 24 pieces of fault information and protective functions. After a fault occurs, the AC drive implements the protection function, and displays the fault code on the operation panel (if the operation panel is available).

Before contacting HNC Electric for technical support, you can first determine the fault type, analyze the causes, and perform troubleshooting according to the following tables. If the fault cannot be rectified, contact the agent or HNC Electric.

Err22 is the AC drive hardware overcurrent or overvoltage signal. In most situations, hardware overvoltage fault causes Err22.

HV580 Series Frequency Inverter

Table 7-1: Solutions to the faults of the HV580

Fault Name	Display	Possible Causes	Solutions
Inverter unit protection	Err01	<p>1: The output circuit is grounded or short circuited.</p> <p>2: The connecting cable of the motor is too long.</p> <p>3: The module overheats.</p> <p>4: The internal connections become loose.</p> <p>5: The main control board is faulty.</p> <p>6: The drive board is faulty.</p>	<p>1: Eliminate external faults.</p> <p>2: Install a reactor or an output filter.</p> <p>3: Check the air filter and the cooling fan.</p> <p>4: Connect all cables properly.</p> <p>5: Contact the agent or HNC Electric.</p> <p>6: Contact the agent or HNC Electric.</p> <p>7: Contact the agent or HNC Electric.</p>
Overcurrent during acceleration	Err02	<p>1: The output circuit is grounded or short circuited.</p> <p>2: Motor auto-tuning is not performed.</p> <p>3: The acceleration time is too short.</p> <p>4: Manual torque boost or V/F curve is not appropriate.</p> <p>5: The voltage is too low.</p> <p>6: The startup operation is performed on the rotating motor.</p> <p>7: A sudden load is added during acceleration.</p> <p>8: The AC drive model is of too small power class.</p>	<p>1: Eliminate external faults.</p> <p>2: Perform the motor auto-tuning.</p> <p>3: Increase the acceleration time.</p> <p>4: Adjust the manual torque boost or V/F curve.</p> <p>5: Adjust the voltage to normal range.</p> <p>6: Select rotational speed tracking restart or start the motor after it stops.</p> <p>7: Remove the added load.</p> <p>8: Select an AC drive of higher power class.</p>

### HV580 Series Frequency Inverter

Fault Name	Display	Possible Causes	Solutions
Overcurrent during deceleration	Err03	<ol style="list-style-type: none"> <li>1: The output circuit is grounded or short circuited.</li> <li>2: Motor auto-tuning is not performed.</li> <li>3: The deceleration time is too short.</li> <li>4: The voltage is too low.</li> <li>5: A sudden load is added during deceleration.</li> <li>6: The braking unit and braking resistor are not installed.</li> </ol>	<ol style="list-style-type: none"> <li>1: Eliminate external faults.</li> <li>2: Perform the motor auto-tuning.</li> <li>3: Increase the deceleration time.</li> <li>4: Adjust the voltage to normal range.</li> <li>5: Remove the added load.</li> <li>6: Install the braking unit and braking resistor.</li> </ol>
Overcurrent at constant speed	Err04	<ol style="list-style-type: none"> <li>1: The output circuit is grounded or short circuited.</li> <li>2: Motor auto-tuning is not performed.</li> <li>3: The voltage is too low.</li> <li>4: A sudden load is added during operation.</li> <li>5: The AC drive model is of too small power class.</li> </ol>	<ol style="list-style-type: none"> <li>1: Eliminate external faults.</li> <li>2: Perform the motor auto-tuning.</li> <li>3: Adjust the voltage to normal range.</li> <li>4: Remove the added load.</li> <li>5: Select an AC drive of higher power class.</li> </ol>
Overvoltage during acceleration	Err05	<ol style="list-style-type: none"> <li>1: The input voltage is too high.</li> <li>2: An external force drives the motor during acceleration.</li> <li>3: The acceleration time is too short.</li> <li>4: The braking unit and braking resistor are not installed.</li> </ol>	<ol style="list-style-type: none"> <li>1: Adjust the voltage to normal range.</li> <li>2: Cancel the external force or install a braking resistor.</li> <li>3: Increase the acceleration time.</li> <li>4: Install the braking unit and braking resistor.</li> </ol>
Overvoltage during deceleration	Err06	<ol style="list-style-type: none"> <li>1: The input voltage is too high.</li> <li>2: An external force drives the motor during deceleration.</li> <li>3: The deceleration time is too short.</li> <li>4: The braking unit and braking resistor are not installed.</li> </ol>	<ol style="list-style-type: none"> <li>1: Adjust the voltage to normal range.</li> <li>2: Cancel the external force or install the braking resistor.</li> <li>3: Increase the deceleration time.</li> <li>4: Install the braking unit and braking resistor.</li> </ol>

### HV580 Series Frequency Inverter

Fault Name	Display	Possible Causes	Solutions
Overvoltage at constant speed	Err07	1: The input voltage is too high. 2: An external force drives the motor during deceleration.	1: Adjust the voltage to normal range. 2: Cancel the external force or install the braking resistor.
Control power supply fault	Err08	The input voltage is not within the allowable range.	Adjust the input voltage to the allowable range.
Under voltage	Err09	1: Instantaneous power failure occurs on the input power supply. 2: The AC drive's input voltage is not within the allowable range. 3: The bus voltage is abnormal. 4: The rectifier bridge and buffer resistor are faulty. 5: The drive board is faulty. 6: The main control board is faulty	1: Reset the fault. 2: Adjust the voltage to normal range. 3: Contact the agent or HNC Electric.
AC drive overload	Err10	1: The load is too heavy or locked-rotor occurs on the motor. 2: The AC drive model is of too small power class.	1: Reduce the load and check the motor and mechanical condition. 2: Select an AC drive of higher power class.
Motor overload	Err11	1: P9-01 is set improperly. 2: The load is too heavy or locked-rotor occurs on the motor. 3: The AC drive model is of too small power class.	1: Set P9-01 correctly. 2: Reduce the load and check the motor and the mechanical condition. 3: Select an AC drive of higher power class.
Power input phase loss	Err12	1: The three-phase power input is abnormal. 2: The drive board is faulty. 3: The lightning board is faulty. 4: The main control board is faulty.	1: Eliminate external faults. 2: Contact the agent or HNC Electric.

### HV580 Series Frequency Inverter

Fault Name	Display	Possible Causes	Solutions
Power output phase loss	Err13	1: The cable connecting the AC drive and the motor is faulty. 2: The AC drive's three-phase outputs are unbalanced when the motor is running. 3: The drive board is faulty. 4: The module is faulty.	1: Eliminate external faults. 2: Check whether the motor three-phase winding is normal. 3: Contact the agent or HNC Electric.
Module overheat	Err14	1: The ambient temperature is too high. 2: The air filter is blocked. 3: The fan is damaged. 4: The thermally sensitive resistor of the module is damaged. 5: The inverter module is damaged.	1: Lower the ambient temperature. 2: Clean the air filter. 3: Replace the damaged fan. 4: Replace the damaged thermally sensitive resistor. 5: Replace the inverter module.
External equipment fault	Err15	1: External fault signal is input via DI. 2: External fault signal is input via virtual I/O.	Reset the operation.
Communication fault	Err16	1: The host computer is in abnormal state. 2: The communication cable is faulty. 3: P0-28 is set improperly. 4: The communication parameters in group PD are set improperly.	1: Check the cabling of host computer. 2: Check the communication cabling. 3: Set P0-28 correctly. 4: Set the communication parameters properly
Contactors fault	Err17	1: The drive board and power supply are faulty. 2: The contactor is faulty.	1: Replace the faulty drive board or power supply board. 2: Replace the faulty contactor.
Current detection fault	Err18	1: The HALL device is faulty. 2: The drive board is faulty.	1: Replace the faulty HALL device. 2: Replace the faulty drive board.



### HV580 Series Frequency Inverter

Fault Name	Display	Possible Causes	Solutions
Motor auto-tuning fault	Err19	1: The motor parameters are not set according to the nameplate. 2: The motor auto-tuning times out.	1: Set the motor parameters according to the nameplate properly. 2: Check the cable connecting the AC drive and the motor.
Encoder fault	Err20	1: The encoder type is incorrect. 2: The cable connection of the encoder is incorrect. 3: The encoder is damaged. 4: The PG card is faulty.	1: Set the encoder type correctly based on the actual situation. 2: Eliminate external faults. 3: Replace the damaged encoder. 4: Replace the faulty PG card.
EEPROM read-write fault	Err21	The EEPROM chip is damaged.	Replace the main control board
AC drive hardware fault	Err22	1: Overvoltage exists. 2: Overcurrent exists.	1: Handle based on overvoltage. 2: Handle based on overcurrent.
Short circuit to ground	Err23	The motor is short circuited to the ground.	Replace the cable or motor.
Accumulative running time	Err26	The accumulative running time reaches the setting value.	Clear the record through the parameter initialization function
User-defined fault 1	Err27	1: The user-defined fault 1 signal is input via DI. 2: User-defined fault 1 signal is input via virtual I/O.	Reset the operation.
User-defined fault 2	Err28	1: The user-defined fault 2 signal is input via DI. 2: The user-defined fault 2 signal is input via virtual I/O.	Reset the operation.

### HV580 Series Frequency Inverter

Fault Name	Display	Possible Causes	Solutions
Accumulative power-on time reached	Err29	The accumulative power-on time reaches the setting value.	Clear the record through the parameter initialization function
Load becoming 0	Err30	The AC drive running current is lower than P9-64.	Check that the load is disconnected or the setting of P9-64 and P9-65 is correct.
PID feedback lost during running	Err31	The PID feedback is lower than the setting of PA-26.	Check the PID feedback signal or set PA-26 to a proper value.
Pulse-by-pulse current limit fault	Err40	1: The load is too heavy or locked-rotor occurs on the motor. 2: The AC drive model is of too small power class.	1: Reduce the load and check the motor and mechanical condition. 2: Select an AC drive of higher power class.
Motor switchover fault during running	Err41	Change the selection of the motor via terminal during running of the AC drive.	Perform motor switchover after the AC drive stops.
Too large speed deviation	Err42	1: The encoder parameters are set incorrectly. 2: The motor auto-tuning is not performed. 3: P9-69 and P9-70 are set incorrectly.	1: Set the encoder parameters properly. 2: Perform the motor auto-tuning. 3: Set P9-69 and P9-70 correctly based on the actual situation.
Motor over-speed	Err43	1: The encoder parameters are set incorrectly. 2: The motor auto-tuning is not performed. 3: P9-69 and P9-70 are set incorrectly.	1: Set the encoder parameters properly. 2: Perform the motor auto-tuning. 3: Set P9-69 and P9-70 correctly based on the actual situation.

### HV580 Series Frequency Inverter

Fault Name	Display	Possible Causes	Solutions
Motor overheat	Err45	1: The cabling of the temperature sensor becomes loose. 2: The motor temperature is too high.	1: Check the temperature sensor cabling and eliminate the cabling fault. 2: Lower the carrier frequency or adopt other heat radiation measures.
Initial position fault	Err51	The motor parameters are not set based on the actual situation.	Check that the motor parameters are set correctly and whether the setting of rated current is too small.

## 7.4 Common Faults and Solutions

You may come across the following faults during the use of the AC drive. Refer to the following table for simple fault analysis.

Table 7-2 Troubleshooting to common faults of the AC drive

SN	Fault	Possible Causes	Solutions
1	There is no display at power-on.	1: There is no power supply to the AC drive or the power input to the AC drive is too low. 2: The power supply of the switch on the drive board of the AC drive is faulty. 3: The rectifier bridge is damaged. 4: The control board or the operation panel is faulty. 5: The cable connecting the control board and the drive board and the operation panel breaks.	1: Check the power supply. 2: Check the bus voltage. 3: Re-connect the 8-core and 28-core cables. 4: Contact the agent or HNC Electric for technical support.

HV580 Series Frequency Inverter

SN	Fault	Possible Causes	Solutions
2	"HC" is displayed at power-on.	1: The cable between the drive board and the control board is in poor contact. 2: Related components on the control board are damaged. 3: The motor or the motor cable is short circuited to the ground. 4: The HALL device is faulty. 5: The power input to the AC drive is too low.	1: Re-connect the 8-core and 28-core cables. 2: Contact the agent or HNC Electric for technical support.
3	"Err23" is displayed at power-on.	1: The motor or the motor output cable is short-circuited to the ground. 2: The AC drive is damaged.	1: Measure the insulation of the motor and the output cable with a megger. 2: Contact the agent or HNC Electric for technical support.
4	The AC drive display is normal upon power-on. But "HC" is displayed after running and stops immediately.	1: The cooling fan is damaged or locked-rotor occurs. 2: The external control terminal cable is short circuited.	1: Replace the damaged fan. 2: Eliminate external fault.
5	Err14 (module overheat) fault is reported frequently.	1: The setting of carrier frequency is too high. 2: The cooling fan is damaged, or the air filter is blocked. 3: Components inside the AC drive are damaged (thermal coupler or others).	1: Reduce the carrier frequency (P0-15). 2: Replace the fan and clean the air filter. 3: Contact the agent or HNC Electric for technical support.

HV580 Series Frequency Inverter

SN	Fault	Possible Causes	Solutions
6	The motor does not rotate after the AC drive runs.	1: Check the motor and the motor cables. 2: The AC drive parameters are set improperly (motor parameters). 3: The cable between the drive board and the control board is in poor contact. 4: The drive board is faulty.	1: Ensure the cable between the AC drive and the motor is normal. 2: Replace the motor or clear mechanical faults. 3: Check and re-set motor parameters.
7	The DI terminals are disabled.	1: The parameters are set incorrectly. 2: The external signal is incorrect. 3: The jumper bar across OP and +24 V becomes loose. 4: The control board is faulty.	1: Check and reset the parameters in group P4. 2: Re-connect the external signal cables. 3: Re-confirm the jumper bar across OP and +24 V. 4: Contact the agent or HNC Electric for technical support.
8	The motor speed is always low in CLVC mode.	1: The encoder is faulty. 2: The encoder cable is connected incorrectly or in poor contact. 3: The PG card is faulty. 4: The drive board is faulty.	1: Replace the encoder and ensure the cabling is proper. 2: Replace the PG card. 3: Contact the agent or HNC Electric for technical support.
9	The AC drive reports overcurrent and overvoltage frequently.	1: The motor parameters are set improperly. 2: The acceleration/deceleration time is improper. 3: The load fluctuates.	1: Re-set motor parameters or re-perform the motor auto-tuning. 2: Set proper acceleration/deceleration time. 3: Contact the agent or HNC Electric for technical support.

HV580 Series Frequency Inverter

SN	Fault	Possible Causes	Solutions
10	Err17 is reported upon power-on or running.	The soft startup contactor is not picked up.	<p>1: Check whether the contactor cable is loose.</p> <p>2: Check whether the contactor is faulty.</p> <p>3: Check whether 24 V power supply of the contactor is faulty.</p> <p>4: Contact the agent or HNC Electric for technical support.</p>
11	88888 is displayed upon power-on.	Related component on the control board is damaged.	Replace the control board.

# Appendix A    =    RS-485communication expansion card instruction

## A.1 Overview:

Especially for HV580 series frequency inverter RS485 communication, with separate solution, all specifications are in accordance with international standard.

## A.2 Installation dimension and control terminals details:

1. Dimensions are as below;

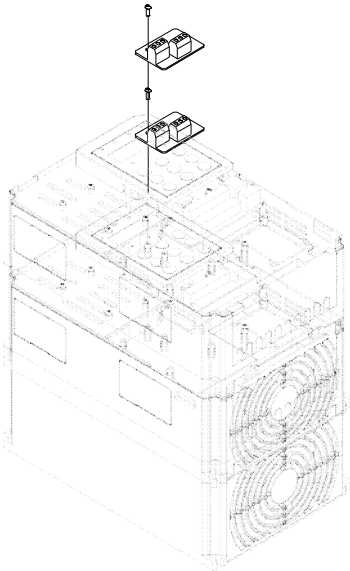

Terminal blocks Terminal Function :

Type Sign	Terminal	Terminal	Function
485 communication (CN1) Jumper description :	485+/485-	Communication port Terminal	485 communication input terminal, separate input
	CGND	485 communication	Power is separate

J3	Jumper position	End terminal resistor
<div style="display: flex; align-items: center;"> <div style="margin-right: 5px;">3</div> <div style="margin-right: 5px;">2</div> <div style="margin-right: 5px;">1</div>  </div>	Short-circuit 2, 3 pin	Not use end terminal resistor (default)
	Short-circuit 1, 2 pin	User end terminal resistor(white point is pin 1)

Cautions :

1. While using RS485 communication, if it's the end inverter, then need to connect end resistor (Jumper J3);
2. To avoid outer interference to the communication signal, suggest use twisted-pair shielded cable on the communication connection, avoid parallel cable.

## Appendix B = HV580 Modbus communication

HV580 series inverter provides the RS485 communication interface, and support the Modbus RTU - from standing communication protocol. Users can through the computer or PLC central control, through the communication protocol Setting frequency converter running commands, modify or read function code parameters, read the inverter working condition and fault information, etc.

### 1. Protocol content

The entire message frame must be used as a continuous stream. If the pause time frame prior to the completion of more than 1.5 byte times, the receiving device will refresh the incomplete message and assumes that the next byte will be the address field of a new message. Similarly, if a new message starts in less than 3.5 bytes times following the previous message, the receiving device will consider it a continuation of the previous message. This will set an error, as the value in the final CRC field will not be valid for the combined messages. A typical message frame is shown below.



**Application mode:**

The inverter accessing with “single main multi-slave” PC/PLC control network, which equipped with RS232/RS485 bus.

Bus structure:

(1)Interface mode

RS232/RS485 hardware interface

(2)Transmission mode

Asynchronous serial, half-duplex transmission. At the same time host and slave computer can only permit one to send data while the other can only receive data. Data in the process of serial asynchronous communication is in the message format and sent one frame by one frame.

(3)Topological mode

In single-master system, the setup range of slave address is 1 to 247. Zero refers to broadcast communication address. The address of slave must be exclusive in the network. That is one condition of one slave machine.

**Communication information structure**

HV580 Modbus protocol communication data format is as below:

Including: starting bit, 8 data bits, parity bit and stop bit.

Starting bit	Bit1	Bit2	Bit3	Bit4	Bit5	Bit6	Bit7	Bit8	Parity bit	Stop bit
--------------	------	------	------	------	------	------	------	------	------------	----------

The entire message frame must be used as a continuous stream. If the pause time frame prior to the completion of more than 1.5 byte times, the receiving device will refresh the incomplete message and assumes that the next byte will be the address field of a new message. Similarly, if a new message starts in less than 3.5 bytes times following the previous message, the receiving device will consider it a continuation of the previous message. This will set an error, as the value in the final CRC field will not be valid for the combined messages. A typical message frame is shown below.

**RTU frame format :**

START	3.5-character time
Slave address ADDR	Communication address: 1~247

## HV580 Series Frequency Inverter

Command code CMD	03H: Read slave parameters ; 06H: Write slave parameters 08H: Loop since detection
DATA	Function code parameter address, function code parameter number, function code parameter value, etc.
CRC CHK low order	Detection value: CRC value
CRC CHK high order	
END	At least 3.5-character time

In the RTU mode, a new frame to at least 3.5 bytes transmission time interval as a start. And then transfer the data fields in the order: from the machine address, operation command code, data and CRC check words, each domain bytes are hex 0... 9, A, F. Continuously detect network bus network facilities, including pause interval of time. When receiving the first field (address information), each network device to decrypt the byte to determine whether to own. A byte at the end of transmission is complete, and with a 3.5 bytes of transmission time interval at least to indicate the end of the frame, in the later, can start a new message.

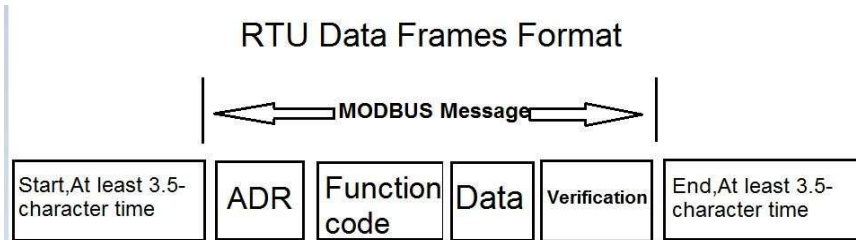

### Command code and communication data description

Command code: 03H, read N (Word), maximum continuously read 12 words.

For example the inverter start address P0.02 of the slave machine address 01 continuously reads two consecutive values.

### RTU Host Commands:

ADR	01H
CMD	03H
Start address high order	P0H
Start address low order	02H

**HV580 Series Frequency Inverter**

Register number high order	00H
Register number low order	02H
CRC CHK low order	CRC CHK values to be calculated
CRC CHK high order	

**RTU salve response**

PD-05 set "0":

ADR	01H
CMD	03H
Byte number high order	00H
Byte number low order	04H
Data P002H high order	00H
Data P002H low order	00H
Data P003H high order	00H
CRC CHK low order	01H
CRC CHK high order	CRC CHK values to be calculated
CRC CHK low order	

PD-05 set "1":

ADR	01H
CMD	03H
Byte number	04H
Data F002H high order	00H
Data F002H low order	00H
Data F003H high order	00H
Data F003H low order	01H
CRC CHK low order	CRC CHK values to be calculated
CRC CHK high order	

Command code: 06H write a word

For example: Write 5000 (1388H) into P00AH which slave address is 02H.

RTU host commands

### HV580 Series Frequency Inverter

ADR	02H
CMD	06H
Data address high order	P0H
Data address low order	0AH
Data content high order	13H
Data content low order	88H
CRC CHK low order	CRC CHK values to be calculated
CRC CHK high order	

#### RTU salve response

ADR	01H
CMD	06H
Data address high order	P0H
Data address low order	0AH
Data content high order	13H
Data content low order	88H
CRC CHK low order	CRC CHK values to be calculated
CRC CHK high order	

#### Cyclical Redundancy Check -

Cyclical Redundancy Check—CRC mode: CRC(Cyclical Redundancy Check) is in RTU frame format, message contains an error-checking field that is based on a CRC method. The CRC field checks the contents of the entire message. The CRC field is two bytes, containing a 16-bit binary value. The CRC value is calculated by the transmitting device, which appends the CRC to the message. The receiving device recalculates a CRC during receipt of the message, and compares the calculated value to the actual value it received in the CRC field. If the two values are not equal, then results an error. The CRC is started by 0xFFFF. Then a process begins of applying successive 8-bit bytes of the message to the current contents of the register. Only the eight bits of data in each character are used for generating the CRC. Start and stop bits, and the parity bit, do not apply to the CRC.

During generation of the CRC, each eight-bit character is exclusive XOR with the register contents. Then the result is shifted in the direction of the least significant bit (LSB), with a ZERO filled into the most significant bit (MSB) position. The LSB extracted and examined. If the LSB is 1, the register then exclusive XOR with a

preset, fixed value. If the LSB is 0, no exclusive XOR takes place. This process is repeated until 8 shifts have been performed. After the last (8) shift, the next eight-bit byte is exclusive XOR with the register's current value, and the process repeats for 8 more shifts as described above. The final contents of the register, after all the bytes of the message have been applied, is the CRC value.

When CRC appended to the message, the low byte is appended first, and then the high byte.

CRC calculation program:

```
unsigned int crc_chk_value(unsigned char *data_value,unsigned char length)
{
unsigned int crc_value=0xFFFF;
int i;
while(length--)
{
crc_value^=*data_value++;
for(i=0;i<8;i++)
{
if(crc_value&0x0001)
{
crc_value=(crc_value>>1)^0xa001;
}
else
{
crc_value=crc_value>>1;
}
}
}
return(crc_value);
}
```

Communication data address definition:

The chapter is about communication contents, it's used to control the inverter operation, the status of the inverter and related parameter setup. Read and write function code parameters (Some function codes are not able to be changed, only for the manufacturer use.). The mark rules of function code parameters address:

The group number and mark of function codes are parameter address for indication rules.

## HV580 Series Frequency Inverter

High byte: P0~PF (P group), A0~AF (A group), 70~7F (U group) Low byte: 00~FF

For example: P3.12, the address indicates 0xP30C

Caution:

Group PF: Parameters could not be read or be modified.

Group U: Parameters could be read but not be modified.

Some parameters can not be changed during operation; some parameters regardless of the kind of state the inverter in, the parameters can not be changed. Change the function code parameters, pay attention to the scope of the parameters, units, and relative instructions.

Besides, if EEPROM is frequently stored, it will reduce the service life of EEPROM. In some communication mode, function code needn't to be stored as long as changing the RAM value.

Group P: to achieve this function, change high order P of the function code address into 0.

Group A: to achieve this function, change high order A of the function code address to be 4.

Corresponding function code addresses are indicated below:

High byte : 00~0F (P group), 40~4F (A group) Low byte: 00~FF

For example:

Function code P3.12 can not be stored into EEPROM, address indicates to be 030C, function code A0-05 can not be stored in EEPROM, address indicates to be 4005; This address can only act writing RAM, it can not act reading, when act reading, it is invalid address. For all parameters, command code 07H can be used to achieve this function.

### Stop/run parameters:

Parameter add.	Parameter description	Parameter	Parameter description
1000H	* Communication Setting value (decimalism) -10000 ~ 10000	1010H	PID setup
1001H	Running frequency	1011H	PID feedback
1002H	Bus voltage	1012H	PLC process
1003H	Output voltage	1013H	PULSE input pulse frequency, unit 0.01kHz
1004H	Output current	1014H	Feedback speed, unit 0.1Hz
1005H	Output power	1015H	Rest running time
1006H	Output torque	1016H	AI1 voltage before correction
1007H	Running speed	1017H	AI2 voltage before correction

### HV580 Series Frequency Inverter

1008H	DI input status	1018H	AI3 voltage before correction
1009H	DO output status	1019H	Line speed
100AH	AI1 voltage	101AH	Current power on time
100BH	AI2 voltage	101BH	Current running time
100CH	Running speed	101CH	PULSE input pulse frequency, unit 1Hz
100DH	DI input status	101DH	Communication setup value
100EH	DO output status	101EH	Actual feedback speed
100FH	AI1 voltage	101FH	Main frequency X display
-	-	1020H	Auxiliary frequency Y display

**Caution:**

The communication setup value is percentage of the relative value, 10000 corresponds to 100.00%, -10000 corresponds to -100.00%. For data of dimensional frequency, the percentage value is the percentage of the maximum frequency. For data of dimensional torque, the percentage is P2.10, A2.48, A3.48, A4.48 (Torque upper digital setup, corresponding to the first, second, third, fourth motor).

**Control command input to the inverter (write-only)**

Command word address	Command function
2000H	0001 : Forward operation
	0002 : Reverse operation
	0003 : Forward jog
	0004 : Reverse jog
	0005 : Free stop
	0006 : Speed-down stop
	0007 : Fault reset

**Read inverter status : (read-only)**

Status word address	Status word function
3000H	0001 : Forward operation
	0002 : Reverse operation
	0003 : Stop

HV580 Series Frequency Inverter

Parameters lock password check = (if the return is the 8888H, it indicates the password checksum pass)

Password address	Contents of input password
1P00H	****

Digital output terminal control: (write-only)

Command address	Command content
2001H	BIT0 : Y1 Output Control
	BIT1 : DO2 Output control
	BIT2 : RELAY1 output control
	BIT3 : RELAY2 output control
	BIT4 : Y2R output control
	BIT5 : VY1
	BIT6 : VDO2
	BIT7 : VDO3
	BIT8 : VDO4
	BIT9 : VDO5

Analog output AO1 control = (write-

only) Analog output AO2 control =

Command address	Command content
2002H	0 ~ 7FFF means 0%~ 100%

(write-only)

(PULSE) output control = (write-only)

Command address	Command content
2003H	0 ~ 7FFF means 0%~ 100%
Command address	Command content
2004H	0 ~ 7FFF means 0%~ 100%



**Inverter fault description** :

Inverter fault address	Inverter fault information	
8000H	0000 : No fault	0015 : Parameter read and write fault
	0001 : Reserved	0016 : Inverter hardware fault
	0002 : Speed-up over current	0017 : Motor earthing short-circuit fault
	0003 : Speed-down over current	0018 : Reserved
	0004 : Constant speed over current	0019 : Reserved
	0005 : Speed-up over voltage	001A : Running time arrive fault
	0006 : Speed-down over voltage	001B : User defined fault 1
	0007 : Constant speed over voltage	001C : User defined fault 2
	0008 : Buffer resistance overload fault	001D : Power on time arrive fault
	0009 : Under-voltage fault	001E : Load off
	000A : Inverter overload	001F : PID feedback lost during operation
	000B : Motor overload	0028 : Fast current limit timeout fault
	000C : Input phase lost	0029 : Motor shifting fault during operation
	000D : Output phase lost	002A : Excessive speed deviation
	000E : Module overheating	002B : Motor over speed
	000F : External fault	002D : Motor over-temperature
	0010 : Communication fault	005A : Encoder line number setup fault
	0011 : Contactor fault	005B : Encoder not connected
	0012 : Current detection fault	005C : Initial position error
	0013 : Motor tuning fault	005E : Speed feedback fault
0014 : Encoder/PG card fault		

**Pd group communication parameters description**

Pd-00	Baud rate	Default	6005
	Setting range	Digital's bit: MODBUS Baud rate	
		0 : 300BPS 1 : 600BPS 2 : 1200BPS 3 : 2400BPS 4 : 4800BPS	5 : 9600BPS 6 : 19200BPS 7 : 38400BPS 8 : 57600BPS 9 : 115200BPS

This parameter is used to set the data transfer rate between the host computer and the inverter.

Caution: The baud rate of the position machine and the inverter must be consistent.

Or, communication is impossible. The higher the baud rate is, the faster the communication is.

Pd-01	Data format	Default	0
	Setting range	0 : No check: data format <8,N,2> 1 : Even parity check: data format <8,E,1> 2 : Odd parity check: data format <8,O,1> 3 : No check: data format <8-N-1>	

The data format of the position machine and the inverter setup must be consistent, otherwise communication is impossible.

Pd-02	Local address	Default	1
	Setting range	1~247, 0 is broadcast address.	

When the local address is set to 0, that is the broadcast address, achieve position machine's broadcast function. The local address is unique (except for the broadcast address), which is the basis for the position machine and the inverter point to point communication.

Pd-03	Response delay	Default	2ms
	Setting range	0~20ms	

Response delay: It refers to the interval time from the inverter finishes receiving data to sending data to the position machine. If the responses delay is less than the system processing time, the response based on the time delay of the system processing time. If the response delay is more than the system processing time, after the system process the data, it should be delayed to wait until the response delay time is up, then sending data to host machine.

### HV580 Series Frequency Inverter

Pd-04	Communication overtime	Default	0.0 s
	Setting range	0.0 s (invalid); 0.1~60.0s	

When the function set to 0.0s, the communication overtime parameter is invalid.

When the function code is set to valid value, if the interval time between one communication with the next communication exceeded the communications overtime, the system will report communication fault error (fault serial 16= E.CoF1) . Under normal circumstances, it will be set to invalid value. If the system of continuous communication, setting parameters, you can monitor the communication status.

Pd-05	Communication protocol selection	Default	0
	Setting range	0: non standard Modbus protocol 1: Standard Modbus Protocol	

Pd.05=1: Select Standard Modbus protocol.

Pd.05=0: Reading command, the slave returns the number of bytes which has one more byte than the standard Modbus protocol, for specific please refer to the protocol, the part of the "5 communication data structure".

Pd-06	Communication read the current resolution	Default	0
	Setting range	0: 0.01A; 1: 0.1A	

To determine when the communication reads the output current, what the output current value unit is.

## Warranty Agreement

1. The warranty period of the product is 18 months (refer to the barcode on the equipment). During the warranty period, if the product fails or is damaged under the condition of normal use by following the instructions, HNC Electric will be responsible for free maintenance.
2. Within the warranty period, maintenance will be charged for the damages caused by the following reasons:
  - a. Improper use or repair/modification without prior permission
  - b. Fire, flood, abnormal voltage, other disasters and secondary disaster
  - c. Hardware damage caused by dropping or transportation after procurement
  - d. Improper operation
  - e. Trouble out of the equipment (for example, external device)
3. If there is any failure or damage to the product, please correctly fill out the Product Warranty Card in detail.
4. The maintenance fee is charged according to the latest Maintenance Price List of AFI Drives
5. The Product Warranty Card is not re-issued. Please keep the card and present it to the maintenance personnel when asking for maintenance.
6. If there is any problem during the service, contact AFI agent or AFI Drives directly.
7. This agreement shall be interpreted by AFI.

